

# On distinguishability, orthogonality, and violations of the second law: contradictory assumptions, contrasting pieces of knowledge

Piero G. Luca Mana,\* Anders Månsson, and Gunnar Björk  
School of Information and Communication Technology,  
Royal Institute of Technology (KTH), Isaffjordsgatan 22, SE-164 40 Stockholm, Sweden  
(Dated: 24 August 2005)

Two statements by von Neumann and a thought-experiment by Peres prompts a discussion on the notions of one-shot distinguishability, orthogonality, semi-permeable diaphragm, and their thermodynamic implications. In the first part of the paper, these concepts are defined and discussed, and it is explained that one-shot distinguishability and orthogonality are contradictory assumptions, from which one cannot rigorously draw any conclusion, concerning e.g. violations of the second law of thermodynamics. In the second part, we analyse what happens when these contradictory assumptions comes, instead, from *two* different observers, having different pieces of knowledge about a given physical situation, and using incompatible density matrices to describe it.

PACS numbers: 03.65.Ca,65.40.Gr,03.67.-a

## 0. INTRODUCTION: VON NEUMANN (AND PERES) ON ORTHOGONALITY AND THE SECOND LAW

In § V.2 of von Neumann's *Mathematische Grundlagen der Quantenmechanik* [1] (see also [2]) we find the two following propositions:<sup>1</sup>

“[T]wo states  $\phi, \psi$  [...] can certainly be separated by a semi-permeable diaphragm if they are orthogonal”;

and the converse

“[I]f  $\phi, \psi$  are not orthogonal, then the assumption of such a semi-permeable diaphragm contradicts the second law [of thermodynamics]”.

These statements concern thermodynamics and the notions of *distinguishability* and *orthogonality*.

Von Neumann proved the first statement above in an analysis involving “thermodynamic considerations” (the same considerations by which he derived his entropy formula). However, he did not actually prove the second statement, but rather the converse of the first one, viz.: if two “states” can be separated by semi-permeable diaphragms, then they must be orthogonal.

It was Peres [3] that gave a seemingly direct demonstration of the second statement (2) by means of a thought-experiment with ‘quantum gases’ in which he explicitly assumes the non-orthogonality of two quantum “states”, their separability by semi-permeable diaphragms, and from this assumptions creates a thermodynamic cycle which violates the second law.

More precisely, the thought-experiment involves *two* observers: one making the non-orthogonality assumption, the other performing the separation.

The interplay of orthogonality, distinguishability, thermodynamics, and multiplicity of observers is quite interesting; therefore we want to discuss and analyse it in varying depth, mainly with paedagogical purposes. The paper is divided into two main parts, reflecting two main perspectives.

In the first part we offer a discussion on the three concepts of *preparation* and *measurement procedure* and “one-shot” *distinguishability*, and of their mathematical representatives: *density matrix*, *positive-operator-valued measure*, and *orthogonality*. First, we make clear that ‘orthogonality’ is simply the mathematical counterpart of ‘one-shot distinguishability’; thus, one cannot assert or deny the one without asserting or denying the other as well. Second, we show how the idea of a semi-permeable membrane which can separate two preparations (“states”) is just a particular realisation of a measurement procedure which can distinguish, in one shot, those preparations. This will provide an occasion to discuss the relation of these concepts to thermodynamics. The principal conclusion of the first part will be that the second statement (2) — and its demonstration by Peres — contains a contradiction in its premise; i.e., it has the logical form ‘ $(A \wedge \neg A) \Rightarrow B$ ’. The contradiction in the premise is the assumption of distinguishability and non-distinguishability at the same time.

The contradiction in Peres’ experiment, however, can also be conceived as a situation in which *two* scientists use two *different* density matrices to analyse the *same* physical phenomenon. This provides an illustration of the fact that a density matrix adopted to describe a preparation is always dependent on an observer’s particular *knowledge* about that preparation [4, 5, 6, 7, 8, 9, 10, 11, 12, 13, 14, 15, 16, 17, 18], as well as on the sets of preparations and measurements considered by the observer [3, 16, 17, 18, 19]. It also illustrates what can happen when the two observers’ have and *use* different pieces of knowledge, hence different density-matrix assignments. For example, the second law may seemingly be

\*Electronic address: mana@imit.kth.se

<sup>1</sup> “[Z]wei Zustände  $\phi, \psi$  [...] durch semipermeable Wände bestimmt getrennt werden können, wenn sie orthogonal sind”, and “[S]ind  $\phi, \psi$  nicht orthogonal, so widerspricht die Annahme einer solchen semipermeablen Wand dem zweiten Hauptsatz”.

violated for one of the observers. The fact that a mathematical description always depends on one's particular knowledge of a phenomenon, however, is not only true in quantum mechanics, but in classical physics as well. A particular case within thermodynamics was shown by Jaynes' [20] by means of a thought-experiment which is very similar to Peres' and in which the same seeming violation of the second law appears according to one of the observers. For this reason, we shall juxtapose Peres' demonstration to Jaynes', hoping that they will provide insight into each other.

We assume that our reader has a working knowledge of quantum mechanics and thermodynamics (we also provide some footnotes on recent developments of the latter, today better called 'thermomechanics' [21, 22, 23], since they are apparently largely unknown to the quantum-physics community.) We also want to emphasise that this paper is not directly concerned with questions about the relation between thermodynamics and statistical mechanics, nor to questions about "classical" or "quantum" entropy formulae. Since our discussions will regard the second law of thermodynamics, the reader probably expects that entropy will enter the scene; but his or her expectations will not be fulfilled. Peres', von Neumann's, and Jaynes' demonstrations are based on cyclic processes, which start from and end in a situation described by the same *thermodynamic state*.<sup>2</sup> Assuming the entropy to be a state variable, its change is naught in such processes, independently of its mathematical expression. The second law of thermodynamics assumes then the form<sup>3</sup>

$$Q \leq 0 \quad (\text{cyclic processes}), \quad (3)$$

where  $Q$  is the total amount of heat *absorbed* by the thermodynamic body in the process. This is the entropy-free form we are going to use in this paper.

## 1. PART I: CONTRADICTORY PREMISES AND VIOLATIONS OF THE SECOND LAW

*Alice felt even more indignant at this suggestion. "I mean," she said, "that one can't help growing older." [35]*

### 1.1. Preparations and density matrices, measurements and positive-operator-valued measures

We begin by informally recalling the definitions of 'preparation procedure' and 'density matrix', 'measurement procedure' and 'positive-operator-valued measure', and 'one-shot

distinguishability' and 'orthogonality'. In our definitions we follow Ekstein [36, 37], Giles [38, 39, 40], Foulis and Randall [41, 42, 43], Band and Park [44, 45], and Peres [3, 46, 47]; the reader is referred to these references for a deeper discussion (see also [4, 5, 16, 17, 19, 48, 49, 50, 51, 52] and the introductory remarks in Komar [53]).

In quantum theory, a *preparation procedure* (or 'preparation' for short) is "an experimental procedure that is completely specified, like a recipe in a good cookbook" ([3], p. 12, cf. also p. 424). It is usually accompanied by a *measurement procedure*, which can result in different outcomes, appropriately labeled. The probabilities that we assign to the obtainment of these outcomes, for all measurement and preparation procedures, are set as postulates in the theory and encoded in its mathematical objects, described below. Preparation and measurement procedures are not mathematical objects. As an oversimplified example, the instructions for the set-up and triggering of a low-intensity laser constitute a preparation procedure, and the instructions for the installation of a detector constitute a measurement procedure.

A preparation procedure is *mathematically represented* by a *density matrix*<sup>4</sup>  $\varrho$ , whose mathematical properties we assume well known to the reader [3, 52, 55]. A measurement procedure is instead mathematically represented by a *positive-operator-valued measure* (POVM)  $\{E_i\}$ , viz., a set of positive (semi-definite) matrices, each associated to a particular measurement outcome, which sum to the identity matrix [3, 52, 56, 57, 58]. These two mathematical objects encode our knowledge of the statistical properties of their respective preparation and measurement: when we perform an instance of the measurement represented by  $\{E_i\}$  on an instance of the preparation represented by  $\varrho$ , the probability  $p_i$  assigned to the obtainment of outcome  $i$  is given by the trace formula  $p_i = \text{tr}(\varrho E_i)$ .

If we wish to specify not only the probabilities of the various outcomes of a measurement, but also its effect on the preparation, we associate to the measurement procedure a *completely positive map* (CPM) [52, 56, 57, 58, 59]. We shall not use the full formalism of completely positive maps here, however, but only the special case where the CPM is a set of projectors  $\{\Pi_i\}$  and the effect on the density matrix  $\varrho$  when result  $i$  is obtained is given by

$$\varrho \mapsto \varrho'_i = \frac{\Pi_i \varrho \Pi_i}{\text{tr}(\Pi_i \varrho \Pi_i)}. \quad (4)$$

### 1.2. One-shot distinguishability and orthogonality

Suppose a physicist has realised *one instance* of a preparation procedure, choosing between two possible preparation

<sup>2</sup> The concept of 'state' in thermomechanics may include not only the instantaneous values of several (field) variables, but even their histories, or suitably defined equivalence classes thereof. This concept has an interesting historical development. Cf. e.g. Truesdell et al. [24, Preface], Noll [25, 26], Willems [27], Coleman et al. [28, 29, 30, 31] Del Piero et al. [32, 33], Šilhavý [23].

<sup>3</sup> See Serrin [34] for a keen analysis of the second law for cyclic processes.

<sup>4</sup> The original and more apt term was 'statistical matrix', which has unfortunately been changed to 'density matrix' apparently since Wigner [54]; cf. Fano [55].

procedures.<sup>5</sup> We do not know which of the two, but we can perform a measurement on the instance and record the outcome. Suppose there exists a measurement procedure such that some (at least one) of its outcomes have vanishing probabilities for the first preparation and non-vanishing probabilities for the second, while the remaining (at least one) outcomes have vanishing probabilities for the second preparation and non-vanishing probabilities for the first. This means that by performing a *single instance* of this measurement procedure we can deduce *with certainty* which preparation was made, by looking at the outcome. In this case the two preparations are said to be *one-shot distinguishable* (cf. [19]). The fact that some sets of preparation procedures are one-shot distinguishable while others are not is the basic reason why quantum mechanics is a probabilistic theory.

If two preparation procedures are one-shot distinguishable, it is then easy to separate them. By this we mean that if we are presented with many instances of these preparations, we can for each instance make a measurement and tell the preparation, and thus separate the instances of the first preparation from the instances of the second preparation. But the converse is also true: if we can separate with certainty the two groups of instances, it means that we can distinguish with certainty the preparation of each instance.

Let us see how the one-shot-distinguishability property is represented mathematically. The two one-shot-distinguishable preparation procedures of the above example are represented by density matrices  $\phi$  and  $\psi$ , and the measurement by a POVM  $\{A_k\}$ . According to the definition of one-shot distinguishability given above, we must be able to write this POVM as  $\{A_k\} = \{E_i, F_j\}$ , with

$$\begin{aligned} \text{tr}(\phi E_i) = 0 \quad \text{and} \quad \text{tr}(\psi E_i) \neq 0 \quad \text{for all } E_i, \\ \text{tr}(\psi F_j) = 0 \quad \text{and} \quad \text{tr}(\phi F_j) \neq 0 \quad \text{for all } F_j. \end{aligned} \quad (5)$$

This is the mathematical form of our definition of one-shot distinguishability.

An important consequence of the equations above is the following: the density matrices  $\phi$  and  $\psi$  must be orthogonal, viz.  $\text{tr}(\phi\psi) = 0$ .<sup>6</sup> We prove this simple theorem in the Appendix.

Thus, *the fact that two preparation procedures are one-shot*

*distinguishable is mathematically represented by the orthogonality of their associated density matrices.* Or, to put it another way, orthogonality is the mathematical representation of one-shot distinguishability. The converse of the mathematical theorem is also true: if two density matrices are orthogonal, then there exists a POVM with the properties (5) above. But to conclude that the represented preparation procedures are one-shot distinguishable, we need first to *assume* that there *physically exists* a measurement procedure corresponding to that POVM.<sup>7</sup>

To prove this theorem (and its converse), thermodynamic arguments are *not* needed. It just follows mathematically from Eqns. (5), which represent a probabilistic property of a measurement. So we begin to see that von Neumann's statement (1), in which he seems to derive orthogonality from separability by semi-permeable diaphragms, would not really need thermodynamic considerations. But we can make this more precise only after we have discussed the notion of a *semi-permeable diaphragm*, which appears in statement (1). This will be done in a moment; before then, we want to make some final remarks about distinguishability and about linguistic details.

It may be the case that two preparation procedures cannot be distinguished by means of a single measurement instance, but can still be distinguished with arbitrary precision by studying their statistical properties, i.e. by analysing the results of an adequately large number of diverse measurements on *separate instances* of these preparations.<sup>8</sup> They are thus distinguishable, *but not in one-shot*. They are represented in this case by *different*, but non-orthogonal, density matrices. On the other hand, two preparation procedures are represented by the *same* density matrix when they have exactly the same statistical properties (with respect to a given set of measurement procedures) and so cannot be distinguished by a statistical analysis of measurement results, no matter how many instances of them we prepare and how many measurements we make.

The whole discussion above is easily generalised to more than two preparation procedures.

### 1.3. Interlude: linguistic details

Preparation procedures are often called 'states'; however, the word 'state' is equally often used to mean the density matrix representing a preparation procedure. This double meaning is quite natural, because the concepts of preparation procedure and density matrix are, as we have seen, strictly related. They are nevertheless distinct, as shown e.g. by the fact that *different* preparation procedures (concerning the same physical phenomenon) can sometimes be represented by the

<sup>5</sup> Note the difference between a preparation (or measurement) procedure, and the realisation of an instance thereof. The first is a set of instructions, a description, the latter is a single actual realisation of those instructions. This terminology may help avoiding the confusion which some authors (see e.g. [60, 61, 62]) still make between 'ensemble' and 'assembly', as defined and conceptually distinguished by e.g. Peres [3, pp. 25, 59, 292] (see also Ballentine [48, p. 361]). The term 'ensemble' is used with so different meanings in the literature (see e.g. Hughston et al. [63] for yet another, though self-consistent, usage), that we prefer to avoid it altogether. Moreover, Bayesian probability theory (see e.g. [10, 64]) makes the conceptual usefulness of this term questionable or at least obsolete.

<sup>6</sup> This expression is the usual definition of orthogonality, i.e. vanishing scalar product, between vectors: in our case the density matrices are considered as vectors in a real vector space of Hermitian matrices, with  $\text{tr}(\phi\psi)$  as the scalar product.

<sup>7</sup> This is not a light assumption; cf. e.g. Peres [3], pp. 50 and 424.

<sup>8</sup> See e.g. [65, 66, 67, 68, 69, 70, 71, 72]; cf. also [13, 14].

same density matrix. We wish to keep this distinction in this paper, and we shall thus stick to the two distinct terms, avoiding the term ‘state’.

The terms ‘(one-shot) distinguishable’ and ‘orthogonal’ are also often interchanged in an analogous way; e.g., one says that “two preparations are orthogonal” (instead of “two preparations are distinguishable”), or that “two density matrices are distinguishable” (instead of “two density matrices are orthogonal”). Such metonymic expressions are of course handy and acceptable, but we must not forget that ‘orthogonal preparations’ only means ‘one-shot distinguishable preparations’, so that if we say “these preparations are one-shot distinguishable and non-orthogonal” we are then contradicting ourselves — not an experimental or physical contradiction, but a *linguistic*, or *logical*, one. Just as it would be contradictory to say that a classical force field is conservative and its integral along a closed path does not vanish; or that, in a given reference frame, a point-like body is in motion and its position-vector is constant; or that a non-relativistic system is closed and its total mass is changing.

These remarks are pedantic, and many a reader will consider them only linguistic nit-picking; but these readers are then invited to take again a look at von Neumann’s second statement (2). Is everything in order there? We shall come back to this point later.

#### 1.4. “Quantum” ideal gases and semi-permeable diaphragms

In order to analyse a statement which involves, besides quantum concepts, also thermodynamic arguments and semi-permeable diaphragms, it is necessary to introduce a thermodynamic body possessing “quantum” characteristics, i.e., quantum degrees of freedom; an ‘ideal’ body will do very well. For this purpose, we shall first recall the basic relationships between work and heat for classical ideal gases. We shall then follow von Neumann [1] and introduce the quantum degrees of freedom as “internal” degrees of freedom of the particles constituting the gases, and shall finally discuss how the interaction between the quantum and thermodynamic parameters is achieved by means of semi-permeable diaphragms.

Let us first recall that (classical) ideal gases are defined as homogeneous, uniform thermodynamic bodies characterisable by two thermodynamic variables: the volume  $V > 0$  and the temperature  $T > 0$ , and for which the internal energy is a function of the variable  $T$  alone;<sup>9</sup> this implies, via the first law of thermodynamics, that in any isothermal process the heat *absorbed by the gas*,  $Q$ , is always equal to the work

*done by the gas*,  $W$ :

$$Q = W = NkT \ln(V_f/V_i) \quad (\text{isothermal processes}), \quad (6)$$

where  $V_i$  and  $V_f$  are the volumes at the beginning and end of the process,  $k$  is Boltzmann’s constant, and  $N$  is the (constant) number of particles. This formula will be true throughout the paper, as we shall only consider isothermal processes. (Note that  $W$  and  $Q$  can assume both positive and negative values.)

One often considers several samples of such ideal gases in a container and inserts, moves, or removes impermeable or semi-permeable diaphragms<sup>10</sup> at any position one pleases.<sup>11</sup> What the presence of these diaphragms, both in practice and in theory, really signifies in the case of ideal, non-interacting (e.g. non chemically reacting) gas samples, is that we can control and monitor the variables of the ideal-gas samples,  $(V_1, T_1; V_2, T_2; \dots)$  independently of each other, even when some of the samples occupy identical regions of space simultaneously. Thus, the problem becomes equivalent to one where all gas samples always occupy distinct regions of space, even though they may be in mechanical or thermal contact.<sup>12</sup> For “quantum” ideal gases, as will be seen in a moment, the situation is not so simple.

We must first face the question of how to introduce and mathematically represent quantum degrees of freedom in an ideal gas. Von Neumann [1, § V.2] used a hybrid classical-quantum description, microscopically modelling a quantum ideal gas as a large number  $N$  of classical particles possessing an “internal” quantum degree of freedom represented by a density matrix  $\varrho$  living in an appropriate density-matrix space. This space and the density matrix are always assumed to be the same for all the gas particles.<sup>13</sup> He then treated two gas samples described by different density matrices as gases of *somehow different chemical species*. This idea had been presented by Einstein [91] eighteen years earlier, but it is important to point out that the “internal quantum degree of freedom” was for Einstein just a “resonator” capable of assuming only discrete energies. This degree of freedom had for him discrete (the original meaning of the adjective ‘quantum’) but otherwise *statistically classical* properties; it was not described by density matrices, and it did not provide non-orthogonality issues. Einstein’s idea was hence less open to problems than von Neumann’s.

<sup>9</sup> See e.g. the excellent little book by Truesdell and Bharatha [73], or Planck [74, §§ 86–91, 232–236], Lewis and Randall [75, chap. VI], Partington [76, §§ II.54–57, IV.14, VIIA.21], Callen [77, §§ 3-4, 13-1–2, 16-10], Buchdahl [78, §§ 71, 82]; also Samohýl [22, §§ 5, 6].

<sup>10</sup> Partington [76, § 28] informs us that these were first used in thermodynamics by Gibbs [79].

<sup>11</sup> In the limit, this leads to a formalism involving field quantities (cf. Buchdahl [78, §§ 46, 75], and see e.g. Truesdell [21, lectures 5, 6 and related appendices] and [22, 80, 81, 82, 83]), as indicated by the possibility of introducing as many diaphragms as we wish and hence to control smaller and smaller portions of the gas samples.

<sup>12</sup> In particular, the samples have separate entropies and must separately satisfy the second law [79]. When the gases *do* interact, we enter into the more complex, and still under development, thermomechanic theory of mixtures (see e.g. [21, 22, 82, 83, 84, 85, 86, 87, 88]; cf. also [89]).

<sup>13</sup> Dieks and van Dijk [90] point rightly out that one should then more correctly consider the total density matrix  $\bigotimes_{i=1}^n \varrho$ , where  $n = NN_A$  (with  $N_A$  Avogadro’s constant) is their total number.

In fact, von Neumann's conceptual device presents some problems. For example, the chemical species of a gas is not a thermodynamic variable, and even less a continuous one: chemical differences cannot change *continuously* to zero.<sup>14</sup> It would then seem more appropriate to describe a quantum ideal gas by the variables  $(V, T, \rho)$  instead, taking values on appropriate sets. That this would indeed be the only correct treatment can be seen from the fact that the thought experiments considered by von Neumann and reproduced below always involve some step in which the density matrix  $\rho$  of a gas is *changed*. This implies that  $\rho$  is something which we can and *need* to control, and as such it should be included in the list of variables which *define* our thermodynamic system [93].

However, in the following discussion we shall follow von Neumann and Peres instead and speak of a ' $\phi$ -gas', or a ' $\psi$ -gas', etc., where  $\phi$  or  $\psi$  are the density matrices describing the internal quantum degrees of freedom of the gas particles, just as if we were speaking of gases of different chemical species (like e.g. 'argon' and 'helium'). The thermodynamic variables are  $(V, T)$  for each such gas.

In this framework, semi-permeable diaphragms have different meaning and function than they have in the classical framework. This becomes clear when we analyse how they are modelled microscopically. The microscopic picture [1, p. 196][3, p. 271] is, paraphrasing von Neumann, to construct many "windows" in the diaphragm, each of which is made as follows. Each particle of the gases is detained there and a *measurement* is performed on its quantum degrees of freedom; depending on the measurement result, the particle penetrates the window or is reflected, and its density matrix is *changed* in an appropriate way. In other words, the diaphragm also acts on the translational degrees of freedom, *separating* the particles having different preparations spatially, with an efficiency which depends on the preparations and the implemented measurement. This implies that the number of particles and hence the pressures or volumes of the gases on the two sides of the semi-permeable diaphragm will vary, and may set the diaphragm in motion, producing work (e.g. by lifting a weight which loads the diaphragm). There arises thus a kind of mutual dependence between the quantum degrees of freedom and the thermodynamic parameters (like the volume  $V$ ) of the quantum ideal gases. We see that for quantum gases the semi-permeable diaphragms not only make the existence of separate thermodynamic variables for different gas samples possible, as it happened for (non-interacting) classical gases, but also perform transformations of the (not thermodynamically reckoned) quantum variable  $\rho$ .

Such a diaphragm is then simply *a device which implement a measurement procedure*, and is mathematically described by a given POVM and a CPM.

Let us illustrate how semi-permeable diaphragms work

with two examples.

*First example: one-shot distinguishable preparations*

Imagine a container having volume  $V$  and containing a mixture of  $N/2$  particles of a  $z^+$ -gas and  $N/2$  of a  $z^-$ -gas; i.e., the particles have quantum degrees of freedom represented by the density matrices

$$z^+ \stackrel{\text{def}}{=} |z^+\rangle\langle z^+| \hat{=} \begin{pmatrix} 1 & 0 \\ 0 & 0 \end{pmatrix}, \quad (7)$$

$$z^- \stackrel{\text{def}}{=} |z^-\rangle\langle z^-| \hat{=} \begin{pmatrix} 0 & 0 \\ 0 & 1 \end{pmatrix}, \quad (8)$$

in the usual spin-1/2 notation (Fig. 1, a). These two density matrices represent quantum preparations that can be distinguished in one shot by an appropriate measurement, implemented by two semi-permeable diaphragms as described above. The first is completely opaque to the particles of the  $z^-$ -gas and completely transparent to those of the  $z^+$ -gas; the other is completely opaque to the particles of the  $z^+$ -gas and completely transparent to those of the  $z^-$ -gas. Mathematically they are represented by the two-element POVM  $\{z^\pm\}$  and the CPMs (projections)  $\{\rho \mapsto z^\pm \rho z^\pm / \text{tr}(z^\pm \rho z^\pm)\}$ , as follows.<sup>15</sup> For the first diaphragm:

$$z^+ \mapsto z^+, \text{ let through, with probability } \text{tr}(z^+ z^+) = 1, \quad (9a)$$

$$z^- \mapsto z^-, \text{ reflected, with probability } \text{tr}(z^- z^-) = 1 \quad (9b)$$

$$z^+ \mapsto z^-, \text{ with probability } \text{tr}(z^- z^+) = 0, \quad (9c)$$

$$z^- \mapsto z^+, \text{ with probability } \text{tr}(z^+ z^-) = 0, \quad (9d)$$

and for the second:

$$z^+ \mapsto z^+, \text{ reflected, with probability } \text{tr}(z^+ z^+) = 1, \quad (10a)$$

$$z^- \mapsto z^-, \text{ let through, with probability } \text{tr}(z^- z^-) = 1 \quad (10b)$$

$$z^+ \mapsto z^-, \text{ with probability } \text{tr}(z^- z^+) = 0, \quad (10c)$$

$$z^- \mapsto z^+, \text{ with probability } \text{tr}(z^+ z^-) = 0. \quad (10d)$$

Now imagine we insert these two diaphragms in the container (Fig. 1, a), very near to its top and bottom walls respectively. We push them isothermally toward the middle of

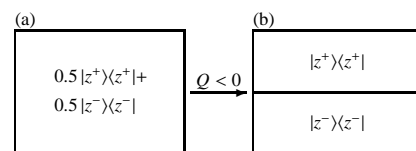

Figure 1: Separation of one-shot-distinguishable quantum gases.

<sup>14</sup> An observation made by Partington [76, § II.28] in a reference to Larmor [92, p. 275].

<sup>15</sup> Due to the large number of gas particles considered, the outcome probabilities are numerically equal, within small fluctuations negligible in the present work, to the average fraction of gas correspondingly transmitted or reflected by the diaphragms.

the container until they come in contact with each other, so that the container is divided in two chambers. By doing so we have separated the two gases, with the  $z^+$ -gas in the upper chamber and the  $z^-$ -gas in the lower one (Fig. 1, b). In order to move these diaphragms and achieve this separation we have spent an amount of work equal to

$$-2 \times \frac{N}{2} kT \ln \frac{V/2}{V} \approx 0.693 NkT, \quad (11)$$

because each diaphragm had to overcome the pressure exerted by the gas to which it is opaque. Since the process is isothermal, the quantity above is also the (positive) amount of heat released by the gases.

The semi-permeable diaphragms can also be used to realise the inverse process, i.e. the mixing of two initially separated  $z^+$ - and  $z^-$ -gases. In this case the expression (11) would be the amount of heat absorbed by the gases as well as the amount of work performed by them.

#### Second example: non-one-shot distinguishable preparations

The quantum degrees of freedom of two gases may also be prepared in such a way that no measurement procedure can distinguish between them in one shot, and so there are no semi-permeable diaphragms which can separate them completely. This has of course consequences for the amount of work that can be gained by using the diaphragms. Imagine again the initial situation above, but this time with a mixture of  $N/2$  particles of a  $z^+$ -gas and  $N/2$  of an  $x^+$ -gas, with

$$\mathbf{x}^+ \stackrel{\text{def}}{=} |x^+\rangle\langle x^+| \hat{=} \frac{1}{2} \begin{pmatrix} 1 & 1 \\ 1 & 1 \end{pmatrix}. \quad (12)$$

The two density matrices  $z^+$  and  $x^+$  are non-orthogonal,  $\text{tr}(z^+ x^+) \neq 0$ , and this must represent the fact that the preparation procedures they represent cannot be distinguished in one shot. This also means that there are no semi-permeable diaphragms which are completely opaque to the particles of the one gas and completely transparent to those of the other gas and vice versa. Mathematically this is reflected in the non-existence of a POVM with the properties (5). The absence of such completely separating diaphragms implies that we cannot control their mixing in a reversible way.

It can be shown [1, 3] that in this case the separating process requiring the minimum amount of work, and so the maximum (negative) amount of heat absorbed by the gas,<sup>16</sup> can be performed by two diaphragms represented by the two-element POVM  $\{\alpha^\pm\}$  and the CPMs (projections)  $\varrho \mapsto$

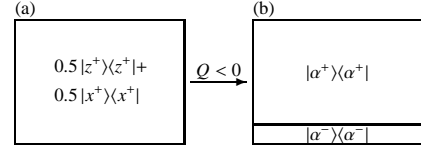

Figure 2: Separation of non-one-shot-distinguishable quantum gases.

$\alpha^\pm \varrho \alpha^\pm / \text{tr}(\alpha^\pm \varrho \alpha^\pm)$ , with

$$\alpha^\pm \stackrel{\text{def}}{=} |\alpha^\pm\rangle\langle \alpha^\pm| \hat{=} \frac{1}{4} \begin{pmatrix} 2 \pm \sqrt{2} & \pm \sqrt{2} \\ \pm \sqrt{2} & 2 \mp \sqrt{2} \end{pmatrix}, \quad (13)$$

$$|\alpha^\pm\rangle \stackrel{\text{def}}{=} (2 \pm \sqrt{2})^{-\frac{1}{2}} (|z^+\rangle \pm |x^+\rangle) \equiv \frac{1}{2} [\pm (2 \pm \sqrt{2})^{\frac{1}{2}} |z^+\rangle + (2 \mp \sqrt{2})^{\frac{1}{2}} |z^-\rangle], \quad (14)$$

i.e., the Hilbert-space vectors  $|\alpha^\pm\rangle$  are the eigenvectors of the matrix  $\lambda$  given by

$$\lambda \stackrel{\text{def}}{=} \frac{1}{2} z^+ + \frac{1}{2} x^+ = \frac{2 + \sqrt{2}}{4} \alpha^+ + \frac{2 - \sqrt{2}}{4} \alpha^- \hat{=} \frac{1}{4} \begin{pmatrix} 3 & 1 \\ 1 & 1 \end{pmatrix}, \quad (15)$$

and they are orthogonal:  $\text{tr}(\alpha^+ \alpha^-) = 0$ . The action of the first diaphragm is thus

$$z^+ \mapsto \alpha^+, \text{ let through, with probability } \text{tr}(\alpha^+ z^+) \approx 0.854, \quad (16a)$$

$$z^+ \mapsto \alpha^-, \text{ reflected, with probability } \text{tr}(\alpha^- z^+) \approx 0.146, \quad (16b)$$

$$x^+ \mapsto \alpha^+, \text{ let through, with probability } \text{tr}(\alpha^+ x^+) \approx 0.854, \quad (16c)$$

$$x^+ \mapsto \alpha^-, \text{ reflected, with probability } \text{tr}(\alpha^- x^+) \approx 0.146, \quad (16d)$$

while for the second diaphragm:

$$z^+ \mapsto \alpha^+, \text{ reflected, with probability } \text{tr}(\alpha^+ z^+) \approx 0.854, \quad (17a)$$

$$z^+ \mapsto \alpha^-, \text{ let through, with probability } \text{tr}(\alpha^- z^+) \approx 0.146, \quad (17b)$$

$$x^+ \mapsto \alpha^+, \text{ reflected, with probability } \text{tr}(\alpha^+ x^+) \approx 0.854, \quad (17c)$$

$$x^+ \mapsto \alpha^-, \text{ let through, with probability } \text{tr}(\alpha^- x^+) \approx 0.146. \quad (17d)$$

By inserting these diaphragms in the container as in the preceding example, they will *transform* and separate into two chambers our  $z^+$ - and  $x^+$ -gases, leaving in the end an  $\alpha^+$ -gas in the upper chamber and an  $\alpha^-$ -gas in the lower one (Fig. 2). The gases will have the same pressure as the original ones but occupy unequal volumes, because the ratio for the  $z^+$ - and  $x^+$ -gases to be transformed into an  $\alpha^+$ -gas and an  $\alpha^-$ -gas was approximately 0.854/0.146, as seen from Eqns. (16); this will

<sup>16</sup> Readers interested in entropy questions should note that such process is irreversible and that *there is no reversible process* with the same initial and final thermodynamic states, as discussed by Dieks and van Dijk [90].

also be the ratio of the final volumes. The total amount of work we spent for this separation is

$$-0.146 NkT \ln \frac{0.146 V}{V} - 0.854 NkT \ln \frac{0.854 V}{V} \approx 0.416 NkT \quad (18)$$

(the first term is for the upper diaphragm, opaque to the  $\alpha^-$ -gas, and the second for the lower diaphragm, opaque to the  $\alpha^+$ -gas). This is also the amount of heat released by the gases.

The significance of the equations above is that the half/half mixture of  $\alpha^+$ - and  $\alpha^-$ -gases can be treated as a 0.854/0.146 mixture of an  $\alpha^+$ -gas and an  $\alpha^-$ -gas. In fact, the two semi-permeable diaphragms could be used to completely separate an  $\alpha^+$ -gas from an  $\alpha^-$ -gas, whose preparations are one-shot distinguishable.

We shall see an application of the coupling between the thermomechanic and quantum degrees of freedom provided by semi-permeable diaphragms in the second part of the paper. For the moment, we want to stress the following two-way connexion: the existence of a measurement which can distinguish two preparations in one shot implies the possibility of constructing a semi-permeable diaphragm which can distinguish and separate the two preparations. Vice versa, if we had such a diaphragm we could use it as a measurement device to distinguish in one shot the two preparations, and so it would imply their one-shot distinguishability.

The notion of a semi-permeable diaphragm implies of course something more, viz., the possibility of a coupling between the quantum degrees of freedom to be distinguished and the translational degrees of freedom. It is this coupling, done with a hybrid quantum-classical framework (von Neumann [1] and the present paper) or completely within quantum mechanics (Peres [3]), that allows applications and consequences of thermodynamic character. However, the two-way connexion pointed out above is independent of the fact that the diaphragm may *also* have applications or consequences of thermodynamic character.

### 1.5. Distinguishability, orthogonality, and the second law

We can now summarise the observations and results that we have gathered up to now:

The existence of a measurement which can distinguish two preparation procedures in one shot is equivalent to the existence of semi-permeable diaphragms which can separate the two preparations, and is also equivalent, by definition, to saying that the two preparations are one-shot distinguishable. Mathematically, the measurement and the diaphragms are then represented by a POVM satisfying Eqns. (5), or equivalently by the orthogonality of the density matrices representing the two preparations.

Let us now look again at the two statements (1) and (2). We understand that, by “state”, von Neumann meant a density

matrix (or a Hilbert-space ray, which can be considered as a particular case thereof).

The first statement (1),

“Two [density matrices]  $\phi$ ,  $\psi$  can certainly be separated by a semi-permeable diaphragm if they are orthogonal”,

seems to be saying just this: the orthogonality of two density matrices (*represents* (mathematically) the fact that their respective preparation procedures are one-shot distinguishable, i.e., can be separated by some device. The demonstration of this statement does not really require thermodynamic arguments, as we have seen.<sup>17</sup>

The second statement was:

“If [the density matrices]  $\phi$ ,  $\psi$  are not orthogonal, then the assumption of such a semi-permeable diaphragm [which can separate them] contradicts the second law of thermodynamics”.

Let us now try to analyse it. The statement mix together mathematical concepts (density matrices, non-orthogonality) and physical ones (semi-permeable diaphragm), so we may try to state it either in physical or in mathematical terms only.

Saying that two density matrices are not orthogonal is the mathematical way of saying that their corresponding preparation procedures are not one-shot distinguishable. So the statement becomes:

If two preparations are not one-shot distinguishable, then the assumption of a semi-permeable diaphragm which can separate them contradicts the second law.

But in the previous sections we have shown that assuming the existence of a separating semi-permeable diaphragm is equivalent by construction to assuming the existence of a measurement which can distinguish the preparations in one shot. So what the second statement is saying is just the following:

If two preparations are *not* one-shot distinguishable, then the assumption that they *are* one-shot distinguishable contradicts the second law.

So the statement assumes that two preparations are one-shot distinguishable *and* not one-shot distinguishable; or in mathematical terms, that their density matrices are orthogonal *and* not orthogonal. It has the logical form ‘ $(A \wedge \neg A) \Rightarrow B$ ’, and makes thus little sense, because it starts from contradictory premises. In particular, it cannot have any physical implications for the second law of thermodynamics. We must

<sup>17</sup> What von Neumann’s demonstration of the first statement really shows is something else: viz., that his quantum entropy expression is consistent with thermodynamics. This, however, does not concern us in the present paper, and will perhaps be analysed elsewhere [93].

in fact remember that, in a logical formal system, from contradictory assumptions ( $A \wedge \neg A$ ) one can idly deduce any proposition whatever ( $B$ ) as well as its negation ( $\neg B$ ) (see e.g. [94, 95, 96]).

The same contradictory premises are also present in Peres' demonstration of the second statement by means of a thought-experiment. This experiment will be discussed in detail in the second part of this paper, for a different purpose. But we can anticipate its basic idea only in order to see where the contradictory premises lie:

A container is divided into two chambers containing two quantum-ideal-gas samples. These are represented by *non-orthogonal* density matrices. Two semi-permeable diaphragms are then used to *completely separate* the two samples, isothermally, just as in the first example of § 1.4. In this way some heat is absorbed by the gases, or equivalently, some work is done by them. The process is then completed so as to come back to the initial situation, and it is easily shown that a net amount of heat is absorbed by the gases (or a net amount of work done by them), violating the second law.

The contradictory premises are the following. It is assumed, on the one hand, that the two initial preparations of the quantum-gas samples are *not* one-shot distinguishable, as is reflected by the use of non-orthogonal density matrices; i.e., that there does *not* exist a measurement procedure able to distinguish and separate them in one shot. On the other hand, it is assumed immediately thereafter that there *is* such a measurement procedure, as is reflected by the existence of the separating diaphragms which must necessarily implement it; in particular, the quantum-gases have then to be represented by *orthogonal* density matrices. This is a contradiction of course, and it has nothing to do with thermodynamic, work extraction, or heat absorption. The thought-experiment cannot be continued if we do not state clearly which of the mutually exclusive alternatives, one-shot distinguishability or not-one-shot distinguishability, i.e. orthogonality or non-orthogonality, is the one meant to hold.

Note that we are *not* saying that there are *no* relationships or valid consistency considerations between quantum mechanics and thermodynamics. In fact, what many of von Neumann's and Peres' analyses and thought-experiments really demonstrate is that the quantum-mechanical physical concepts and principles are consistent with the thermodynamic ones, which is a fundamental result. As Peres [3, p. 275] states it, "It thus appears that thermodynamics imposes severe constraints on the choice of fundamental axioms for quantum theory".<sup>18</sup> What we are saying is that the existence of a semi-permeable diaphragm that can separate two preparations, and the non-one-shot distinguishability of these preparations, are contra-

dictory assumptions *within* the quantum-mechanical theory itself, and so cannot be simultaneously used to study the consistency of this theory with another one (thermodynamics). Using an example given in § 1.3: we can discuss the consistency of a particular microscopic force field with macroscopic thermodynamic laws; but it is vain to assume that the force field is conservative and its integral along a closed path does not vanish in order to derive a violation of the second law — these assumptions are contradictory by definition and anything can be vacuously derived from them.

Peres' thought-experiment, though, does not lose its value because of its contradictory premises. The reason lies in its subtle (and nice) presentation: not as an impersonal reasoning, but as an *interplay* between *two observers* (us and a "wily inventor", as Peres calls him [3, p. 275]). It is thus possible to re-interpret the contradictory premises as *different, contrasting pieces of knowledge* of two observers. This will be now done in the second part of the paper.

## 2. PART II: CONTRASTING PIECES OF KNOWLEDGE AND VIOLATIONS OF THE SECOND LAW

*"One can't perhaps," said Humpty Dumpty: "but two can. With proper assistance, you might have left off at seven." [35]*

### 2.1. The dependence of a density matrix on the observer's knowledge and on the set of preparations and measurements chosen

The fact that a density matrix always depends on the particular knowledge about the properties of the preparation it represents, has been stressed amongst others by Kemble [4, p. 1021][5, pp. 1155–57], Jaynes [6, 7, 8, 9, 10], Caves et al. [11, 12, 14, 15], and ourselves [16, 17, 18].<sup>19</sup> Discussions and analyses of the compatibility of density-matrix assignments by different observers have already been offered, e.g., by Brun et al. [13], and Caves et al. [14].

Note in particular that a density matrix can be associated to a preparation (and a POVM to a measurement) only *after* we have specified the *whole* sets of preparation and measurement procedures we want or have to consider — indeed, it is quite appropriate to say that these sets *define* our 'system'. This might appear paradoxical to some, but is clearly reflected in the fact that, in the description of a phenomenon, we always have to choose a particular Hilbert space before introducing any density matrix. This fact can be inferred from Peres' [3]

<sup>18</sup> We thank an anonymous reviewer for the *American Journal of Physics* for pointing out this passage to us. In the same paragraph, Peres also mentions a *petitio principii* which, however, concerns the proof of the equivalence of the von Neumann and thermodynamic entropies.

<sup>19</sup> Caves, Fuchs, and Schack see the density matrix as a sort of "quantum" analogue of a probability, and develop a "quantum" probability theory in analogy with ("classical") probability theory (with analogous theorems, like e.g. Bayes' and de Finetti's [11, 12, 15, 97, 98, 99, 100]). We should instead prefer to derive the quantum formalism as a *particular* application of probability theory [17, 18].



and Hardy's [19] work, and we have tried to make it mathematically explicit elsewhere [16, 17, 18].

Thus, if we add a single measurement procedure — perhaps a newly discovered one — to the chosen set of measurement procedures, we must in some cases change (numerically and even dimensionally) the density matrices we had previously associated to the preparations.<sup>20</sup>

## 2.2. The value of Peres' thought-experiment from a different perspective

Peres' thought-experiment is particularly suited to show the points above. In its presentation, two observers have contrasting pieces of knowledge about the preparations of the quantum ideal gases: the first observer thinks them not to be one-shot distinguishable, and represents them accordingly by non-orthogonal density matrices; the second observer, instead, knows they are one-shot distinguishable and, in fact, he possesses actual devices — the semi-permeable diaphragms — by which he separates them. This is reflected in the fact that the set of measurement procedures considered by the second observer contains (at least) a measurement (viz., the one which can distinguish in one shot the gas preparations) not contained in the set of the first observer, simply because the first observer did not know about the existence of that measurement.

A similar, two-observer style of presentation was chosen by Jaynes [20, § 6] for a thought-experiment which showed that two different observers may have different pieces of knowledge and so give different thermodynamic descriptions for the same physical situation. When they interact, strange results may arise; e.g., it may appear to one of them as if the other were violating the second law. From this point of view Jaynes' and Peres' thought-experiments are very similar also in their results; the similarity is the more fascinating because Jaynes' experiment is completely within a classical, not quantum, context.

Grad [108, p. 325] also remarked that not only two observers, but even more simply the same observer facing two different applications, may use different pieces of knowledge and descriptions to study the same physical situation.

For this reason, we shall analyse Peres' thought-experiment with the following scheme. First, we present it from the point of view of the first observer, that we call Tatiana, which sees a seeming violation of the second law. Then we go over to Jaynes' simpler thought-experiment, and see how the two observers' (Johann and Marie) contrasting descriptions are resolved there. With the insight provided by Jaynes' experiment, we turn back to Peres', and re-analyse it from the point of view of the second observer, that we call Willard, seeing that he had some additional knowledge and measurement means with respect to Tatiana, and that for him the second law is not violated; on the other hand, Tatiana will have to change the dimensions and numerical values of the density matrices used in her description if she wants to make allowance for Willard's new measurement procedure.<sup>21</sup>

## 2.3. Peres' thought-experiment: Tatiana's description

Peres' demonstration [3, pp. 275–277] can be presented as follows. We are in a quantum laboratory, where the physicist Tatiana is studying a container wherein two quantum-ideal-gas samples are confined to two chambers, having volume  $V/2$  each and separated by an impermeable diaphragm. From some measurements made on a series of identically prepared containers, she has chosen to describe the internal quantum degrees of freedom of the ideal gases by means of the density-matrix space for a quantum two-level system. In her description, the upper chamber contains a  $z^+$ -gas, the lower an  $x^+$ -gas, where  $z^+$  and  $x^+$  are the density matrices defined in § 1.4, Eqns. (7) and (12). They are non-orthogonal,  $\text{tr}(z^+x^+) \neq 0$ , because to Tatiana's knowledge there are no means to distinguish the two corresponding preparations in one shot, as she could not separate the two gases completely with any semi-permeable diaphragms known to her.

Enters a “wily inventor”; let us call him Willard. He claims having produced two such semi-permeable diaphragms, which can completely separate the two gases.<sup>22</sup> In fact, by means of them he reversibly mixes the two gases, *obtaining* work equal to  $Q' = NkT \ln 2 \approx 0.693 NkT$  (cf. Eqn. (11)). From Tatiana's point of view this is quite surprising!

Now she has a single container of volume  $V$  filled with a half/half mixture of  $z^+$ - and  $x^+$ -gases (Fig. 3, b). She wants

<sup>20</sup> This fact is related to the restrictions (“compatibility” or “positivity domains”) of the set of statistical matrices for the “reduced dynamics” of some open quantum systems [101, 102, 103, 104, 105, 106, 107]. These restrictions simply arise because one wants to describe a set of preparation procedures by means of a density-matrix space that is instead only meant for, and is only appropriate for, a particular smaller set. On the other hand, the reason why one wants to do this is that quantum mechanics has the following unfortunate property: if you want to add just one more preparation or measurement procedure to the sets that interest you, you must be ready to “pay” for at least  $2N + 1$  more dimensions for your matrix-spaces, where  $N^2 - 1$  is the dimension of the (normalised-Hermitean-matrix) spaces you were using (i.e., you pay the difference between  $(N + 1)^2 - 1$  and  $N^2 - 1$ ). Compare this with the classical “cost” of only 1 more dimension.

<sup>21</sup> In some situations it might perhaps be necessary to abandon the quantum-theoretical physical principles partially or altogether, in favour of other more economical or aesthetically pleasing. Note that it is easily proven [18] (cf. [16, § V], Holevo [109, chap. I]) that there always exist appropriate (if necessary, infinite-dimensional) quantum-mechanical density-matrix- and POVM-spaces by which one can represent sets of preparation and measurement procedures having *any* statistical properties whatever. In this sense, the quantum-theoretical *mathematical* formalism can never be “proven wrong” (but note that the same also holds for the classical statistical formalism [109, § I.7]), although it may be redundant (see preceding footnote).

<sup>22</sup> This being a scientific paper, we ideally (i.e., unrealistically) assume Willard's honesty and the absence of any fraud.

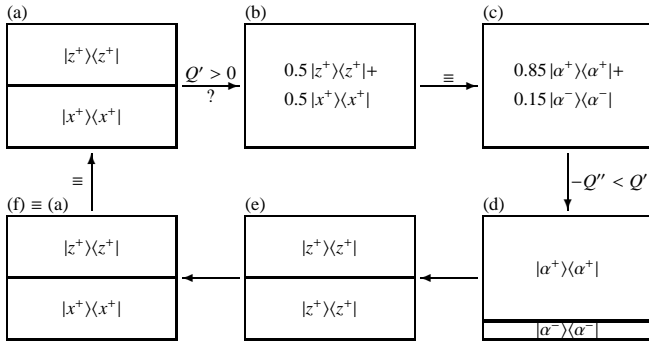

Figure 3: Quantum gas experiment from Tatiana's point of view.

to return to the initial situation, but she cannot use Willard's puzzling means, of course. For her the situation is now the same as that discussed in the second example of § 1.4: the gas mixture is for her equivalent (Fig. 3, d) to a mixture of approximately 0.854 parts of an  $\alpha^+$ -gas and 0.146 parts of an  $\alpha^-$ -gas, where  $\alpha^+$  and  $\alpha^-$  are the density matrices defined in Eqn. (14). Tatiana uses two semi-permeable diaphragms to separate the two  $\alpha^\pm$ -gases, the  $\alpha^+$ -gas into a 0.854 fraction of the volume  $V$ , and the  $\alpha^-$ -gas into the remaining 0.146 fraction (so that they have the same pressure), and *spends* work equal to  $-Q'' = -NkT(0.854 \ln 0.854 + 0.146 \ln 0.146) \approx 0.416 NkT$ , cf. Eqn. (18).

Tatiana then performs two operations corresponding to unitary rotations which reversibly change the density matrices associated to the two gases into the same density matrix, say  $z^+$ , so that the two chambers eventually contain for her the same  $z^+$ -gas. She then eliminates the diaphragms and reinserts another impermeable one in the middle to divide the gas into two chambers of equal volume (Fig. 3, e) — which is, from her point of view, a reversible operation —, and finally performs again an operation represented by a rotation  $z^+ \mapsto x^+$  of the density matrix associated to the gas in the lower chamber. In this way she has apparently re-established the original condition of the gases (Fig. 3, a), which have thus undergone a cycle. The last operations were assumed to be performable without expenditure or gain of work, hence without heat exchange either.<sup>23</sup>

Tatiana summarises the results as follows: a cycle has been

completed because the initial and final situations are the same. The total heat  $Q$  absorbed by the gases equals the work — experimentally measured — done by them and amounts to

$$Q = Q' + Q'' \approx (0.693 - 0.416) NkT = 0.277 NkT > 0. \quad (19)$$

Hence, she sees a violation of the second law (3) because, from her point of view,

$$Q > 0 \quad \text{in the cyclic process.} \quad (20)$$

Tatiana accuses Willard of having violated the second law by means of his strange semi-permeable diaphragms that “completely separate non-orthogonal density matrices”.

Has the second law really been violated? Also from Willard's point of view? We do not answer these questions now; instead, we leave the quantum laboratory where Tatiana and Willard are now arguing after their experiment, and enter an adjacent classical laboratory, where we shall look at Jaynes' demonstration [20]. The situation there is in many respects very similar to the previous one, though it is *completely* “classical”.

## 2.4. Jaynes' thought-experiment

In the classical laboratory, we have a container wherein an ideal-gas sample is equally divided into two chambers of volumes  $V/2$  each and separated by an impermeable diaphragm (Fig. 4, a). From the measurements made by the scientist Johann, the gas in the two chambers is exactly the same, “ideal argon”.<sup>24</sup> For Johann it would thus be impossible, not to say meaningless, to find a semi-permeable diaphragm that be transparent to the gas in the upper chamber and opaque to the gas in the lower one, and another diaphragm with the opposite properties.

The scientist Marie, also in the laboratory, states nevertheless that she has in fact two diaphragms with those very properties. She uses them to reversibly and isothermally mix the two halves of the gas, *obtaining* work equal to  $Q' = NkT \ln 2 \approx 0.693 NkT$  (Fig. 4, b), and leaving Johann stupefied.

In fact, from Johann's point of view Marie has left things exactly as they were: he just needs to reinsert the impermeable diaphragm in the middle of the container and for him the situation is exactly the same as in the beginning: the *one* gas is equally divided into two equal chambers (Fig. 4, c a).

Johann's conclusion is the following: The initial and final conditions of the gas are the same, so a cyclic process has been completed. The work obtained — experimentally measured — equals the heat absorbed by the gas,

$$Q = Q' \approx 0.693 NkT > 0, \quad (21)$$

<sup>23</sup> Von Neumann [1, pp. 194, 197] and Peres [3, p. 275] assert that unitary rotations can be realised without *heat* exchange, but work exchange is allowed and indeed sometimes necessary. However, in our present discussion we have assumed all processes to be isothermal and all gases ideal, which implies that any reversible *isochoric* work exchange (like the unitary rotations) would be accompanied by an equivalent reversible heat exchange (see § 1.4), with a consequent undesired entropy change. This is why Tatiana's final isochoric unitary rotations must be performed with no energy exchange. This issue is related to the problematic way in which the quantum and classical or thermodynamic descriptions are combined; namely, the density matrices are not thermodynamic variables au pair with the real numbers ( $V$  and  $T$ ) describing the gas; cf. § 1.4.

<sup>24</sup> Real argon, of course, behaves like an ideal gas only in certain ranges of temperature and volume.

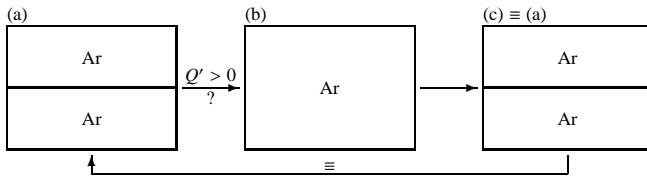

Figure 4: Classical gas experiment from Johann's point of view.

and so for Johann

$$Q > 0 \quad \text{in the cyclic process} \quad (22)$$

(cf. Tatiana's Eqn. (20)), which plainly contradicts the second law of thermodynamics (3).

We see that what happens here is completely analogous to what has happened in the quantum laboratory: a physicist has, from initial measurements, a particular description of a given situation. Then a process takes place that contradicts the physicist's mathematical description, and the re-establishment of what was thought to be the initial situation yields an apparent experimental violation of the second law.

The reader has no doubt noticed that the facts were presented not only from Johann's point of view, but also, so to speak, taking side with him. In fact, we plainly ignored Marie's experimental performance in our mathematical description. But it should be clear that, since the two gas samples in the chambers behaved differently with respect to Marie's semi-permeable diaphragms (one sample exerted pressure on one of the diaphragms but not on the other, and vice versa for the other sample), then they must actually be samples of *two different* gases,<sup>25</sup> contrary to what Johann (and we) believed and described mathematically.

Note that this fact does not completely contradict Johann's point of view. It simply means that the two samples behave exactly in the same manner with respect to Johann's experimental and measurement means, and so he was justified to consider them as samples of the same gas. But now Johann has experimental evidence that the two samples behave differently in certain circumstances, and so, in order to avoid inconsistencies, they *have to* be considered as samples of different gases, at least in all experimental situations in which their difference in behaviour comes about (such as the mixing performed by Marie).

So let us see how the whole process has taken place from Marie's point of view. She explains that the gas samples initially contained in the two chambers were two different kinds of ideal-argon, of which Johann had no knowledge: 'argon *a*' (<sup>a</sup>Ar) and 'argon *b*' (<sup>b</sup>Ar). Argon *a* is soluble in whafnium while argon *b* is not, but the latter is soluble in whifnium,

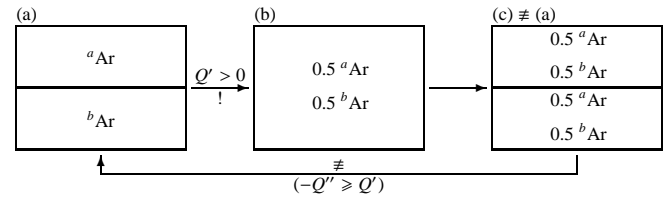

Figure 5: Classical gas experiment from Marie's point of view.

a property not shared by the *a* variety.<sup>26</sup> Marie's separation of the two gases <sup>a</sup>Ar and <sup>b</sup>Ar was possible by means of two semi-permeable diaphragms made of whifnium and whafnium that take advantage of these different properties. (Of course, Jaynes' and our speaking of 'argon *a*', 'argon *b*', 'whafnium', and 'whifnium' in this imaginary experiment is just a coloured way of stating that the two samples are of different gases. The reader can, if he or she so prefers, simply call them 'gas *A*' and 'gas *B*' and take into account their different behaviour with respect to the two semi-permeable diaphragms.)

According to Marie (Fig. 5), the second law is *not* violated: Initially the two gases <sup>a</sup>Ar and <sup>b</sup>Ar were completely separated in the container's two chambers (Fig. 5, a). After her mixing and extracting work, the container contained an equal mixture of <sup>a</sup>Ar and <sup>b</sup>Ar (Fig. 5, b). Upon Johann's reinsertion of the impermeable diaphragm the container was again divided in two equal chambers, but each chamber contained a half/half mixture of <sup>a</sup>Ar and <sup>b</sup>Ar (Fig. 5, c), and this was *different* from the initial condition (Fig. 5, a). Thus *the cycle was not completed, although it appeared so to Johann*, and so the form of the second law for cyclic processes, Eqn. (3), cannot be applied. To close the cycle one has to use the semi-permeable diaphragms again to relegate the two gases to two separate chambers, and must thereby *spend* an amount of work  $-Q''$  at least equal to that previously obtained,  $-Q'' \geq Q'$ , and the second law (3) for the completed cycle is satisfied:  $Q = Q' + Q'' \leq 0$ .

The simple conclusion, stated in terms of entropy, that Jaynes [20, § 3] draws from this demonstration, is that

it is necessary to decide at the outset of a problem which macroscopic variables or degrees of freedom we shall measure and/or control; and within the context of the thermodynamic system thus defined, entropy will be some function  $S(X_1, \dots, X_n)$  of whatever variables we have chosen. We can expect this to obey the second law  $[Q/T \leq \Delta S]$  only as long as all experimental manipulations are confined to that chosen set. If someone, unknown to us, were to vary a macrovariable  $X_{n+1}$  outside that set, he could

<sup>25</sup> Provided, of course, that this phenomenon is also reproducible.

<sup>26</sup> Jaynes [20, § 5] explains that 'whifnium', as well as 'whafnium', "is one of the rare superkalic elements; in fact, it is so rare that it has not yet been discovered".

produce what would appear to us as a violation of the second law, since our entropy function  $S(X_1, \dots, X_n)$  might decrease spontaneously [i.e., without absorption of heat ( $Q = 0$ )], while his  $S(X_1, \dots, X_n, X_{n+1})$  increases.

This is old wisdom: Grad [108, p. 325] (see also [110, 111]) explained thirty-one years earlier that

the adoption of a new entropy is forced by the discovery of new information. [...] The existence of diffusion between oxygen and nitrogen somewhere in a wind tunnel will usually be of no interest. Therefore the aerodynamicist uses an entropy which does not recognise the separate existence of the two elements but only that of “air”. In other circumstances, the possibility of diffusion between elements with a much smaller mass ratio (e.g., 238/235) may be considered quite relevant.

But Jaynes’ and Grad’s remarks do not apply only to entropy; they have greater generality. We always choose some variables — with particular ranges, scales, and governing equations — to describe a physical phenomenon. And such a choice always represents, and is dependent on, the particular knowledge that we have about that phenomenon, or that we think is sufficient to describe it in a given situation or application.<sup>27</sup> This is true in particular for the quantum-mechanical density matrices, Hilbert spaces, and so on.

## 2.5. Peres’ thought-experiment: Willard’s description

With the insight provided by the analysis of the classical experiment and by Grad’s and Jaynes’ remarks, we can return to the quantum laboratory and look with different eyes at what happened there.

Just as in the case of Johann and Marie, we must admit that in the presentation of the quantum experiment we took not only Tatiana’s point of view, but also her parts, disregarding Willard’s experimental evidence in our mathematical description. In fact, Willard showed that the two quantum ideal gases *can* be completely (and, it is assumed, reproducibly) separated; and as shown in § 1.5 this means that there *must* exist a measurement procedure by which the two corresponding quantum preparations can be distinguished in one shot. This is not in complete contradiction with Tatiana’s initial description: with the measurement means at *her* disposal, the two preparation procedures were not distinguishable in one shot,

<sup>27</sup> For an excellent discussion on different levels and scales of description in the particular case of thermodynamics, see Wood [112]; also Samohýl [22, especially § 7] and Jaynes [113, § 1.2].

and so *for her* they were appropriately represented by non-orthogonal density matrices. But, in order to avoid inconsistencies, the two preparation procedures *have to* be represented by orthogonal density matrices in all experimental situations involving the new measurement capability — such as Willard’s mixing process.

Willard thus represents the two quantum ideal gases by orthogonal density matrices, and his mathematical analysis of the thermodynamic process is different from Tatiana’s. Let us follow, step by step, a possible explanation of the quantum-gas process from his point of view. He explains that the internal quantum degrees of freedom of the gases are best represented by the density-matrix space for a quantum four-level system (it might be that the molecules of the gas were diatomic and not mono-atomic as Tatiana believed), of which Tatiana only used a subspace because of her limited measurement means (e.g., she probed the internal quantum degrees of freedom of only one of the molecule’s atoms). In other words, part of the density-matrix space used by Willard was “traced out” in Tatiana’s description, because she had only access to measurement procedures represented by a portion of the total POVM space.

Denoting by  $\{|z^+ z^+\rangle, |z^- z^+\rangle, |z^+ z^-\rangle, |z^- z^-\rangle\}$  the orthonormal basis for the Hilbert space used by Willard, Tatiana could not distinguish, amongst others, the preparations corresponding to  $|z^+ z^+\rangle$  and to  $|z^+ z^-\rangle$ , both of which she represented as  $|z^+\rangle$ , nor those corresponding to  $|x^+ z^+\rangle \stackrel{\text{def}}{=} (|z^+ z^+\rangle + |z^- z^+\rangle) / \sqrt{2}$  and to  $|x^+ z^-\rangle \stackrel{\text{def}}{=} (|z^+ z^-\rangle + |z^- z^-\rangle) / \sqrt{2}$ , which she represented as  $|x^+\rangle$ . Tatiana’s projection is thus of the kind  $|\phi\rangle\langle\psi| \mapsto |\phi\rangle$ :

$$\begin{aligned} |z^+ z^+\rangle &\mapsto |z^+\rangle, & |z^- z^+\rangle &\mapsto |z^-\rangle, \\ |z^+ z^-\rangle &\mapsto |z^+\rangle, & |z^- z^-\rangle &\mapsto |z^-\rangle, \end{aligned} \quad (23)$$

from which also follows

$$\begin{aligned} |x^+ z^+\rangle &\mapsto |x^+\rangle, & |x^- z^+\rangle &\mapsto |x^-\rangle, \\ |x^+ z^-\rangle &\mapsto |x^+\rangle, & |x^- z^-\rangle &\mapsto |x^-\rangle. \end{aligned} \quad (24)$$

From Willard’s point of view, the process went as follows. He had also made some measurements on identically prepared containers, and according to his results, the container’s two chambers initially contained  $\tilde{z}^+$ - and  $\hat{x}^+$ -gases (Fig. 6, a), with

$$\tilde{z}^+ \stackrel{\text{def}}{=} |z^+ z^+\rangle\langle z^+ z^+| \hat{=} \begin{pmatrix} 1 & 0 & 0 & 0 \\ 0 & 0 & 0 & 0 \\ 0 & 0 & 0 & 0 \\ 0 & 0 & 0 & 0 \end{pmatrix}, \quad (25)$$

$$\hat{x}^+ \stackrel{\text{def}}{=} |x^+ z^-\rangle\langle x^+ z^-| \hat{=} \begin{pmatrix} 0 & 0 & 0 & 0 \\ 0 & 0 & 0 & 0 \\ 0 & 0 & 1 & 0 \\ 0 & 0 & 0 & 0 \end{pmatrix}. \quad (26)$$

These density matrices are orthogonal,  $\text{tr}(\tilde{z}^+ \hat{x}^+) = 0$ , because his measurement means allow him to distinguish the two corresponding preparations in one shot. This is precisely what Tatiana could not do, instead, and so she represented the two preparations by the non-orthogonal density matrices  $z^+ = |z^+\rangle\langle z^+|$  and  $x^+ = |z^-\rangle\langle z^-|$ .

Willard mixed the two separable gases with his semi-permeable diaphragms, obtaining work (Fig. 6, b), so that the

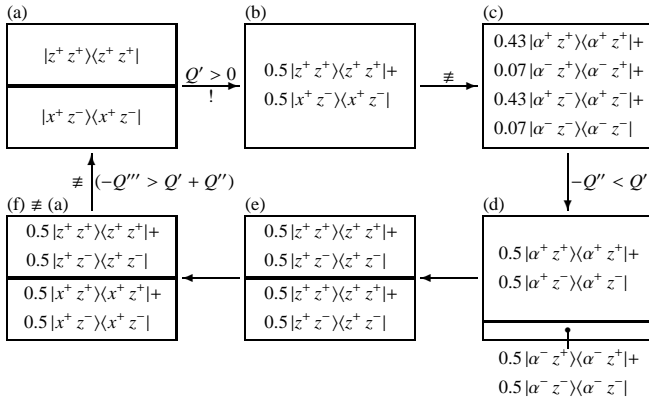

Figure 6: Quantum gas experiment from Willard's point of view.

container eventually contained a  $\tau$ -gas, where

$$\tau = \frac{1}{2}\hat{z}^+ + \frac{1}{2}\hat{x}^+ \triangleq \frac{1}{2} \begin{pmatrix} 1 & 0 & 0 & 0 \\ 0 & 0 & 0 & 0 \\ 0 & 0 & 1 & 0 \\ 0 & 0 & 0 & 0 \end{pmatrix}. \quad (27)$$

Tatiana's subsequent separation by means of her semi-permeable diaphragms (Fig. 6, c d) which can separate the preparations corresponding to  $\alpha^+$  and  $\alpha^-$ , is represented by Willard by the two-element POVM  $\{E^+, E^-\}$ , with

$$E^\pm \stackrel{\text{def}}{=} |\alpha^\pm z^+\rangle\langle\alpha^\pm z^+| + |\alpha^\pm z^-\rangle\langle\alpha^\pm z^-|, \\ \triangleq \frac{1}{4} \begin{pmatrix} 2 \pm \sqrt{2} \pm \sqrt{2} & 0 & 0 \\ \pm \sqrt{2} & 2 \mp \sqrt{2} & 0 \\ 0 & 0 & 2 \pm \sqrt{2} \pm \sqrt{2} \\ 0 & 0 & \pm \sqrt{2} & 2 \mp \sqrt{2} \end{pmatrix}, \quad (28)$$

where

$$|\alpha^\pm z^+\rangle \stackrel{\text{def}}{=} (2 \pm \sqrt{2})^{-\frac{1}{2}} (|z^\pm z^+\rangle \pm |x^\pm z^+\rangle), \quad (29)$$

$$|\alpha^\pm z^-\rangle \stackrel{\text{def}}{=} (2 \pm \sqrt{2})^{-\frac{1}{2}} (|z^\pm z^-\rangle \pm |x^\pm z^-\rangle) \quad (30)$$

(cf. Eqn. (14)), and the associated CPMs (projections)  $\tau \mapsto E^\pm \tau E^\pm / \text{tr}(E^\pm \tau E^\pm)$ .

That separation led to a chamber, with volume 0.854 V, containing the gas *mixture*

$$\frac{1}{2}|\alpha^+ z^+\rangle\langle\alpha^+ z^+| + \frac{1}{2}|\alpha^+ z^-\rangle\langle\alpha^+ z^-|, \quad (31)$$

and another chamber, with volume 0.146 V, containing the gas *mixture*

$$\frac{1}{2}|\alpha^- z^+\rangle\langle\alpha^- z^+| + \frac{1}{2}|\alpha^- z^-\rangle\langle\alpha^- z^-|. \quad (32)$$

Note that Tatiana could not notice that these were mixtures, because of her limited instrumentation. Moreover, from Willard's point of view the separation brought about a transformation of the gases' quantum degrees of freedom.

The following step corresponded to the unitary rotations

$$|\alpha^+ z^+\rangle\langle\alpha^+ z^+| \mapsto |z^+ z^+\rangle\langle z^+ z^+|, \quad (33)$$

$$|\alpha^+ z^-\rangle\langle\alpha^+ z^-| \mapsto |z^+ z^-\rangle\langle z^+ z^-| \quad (34)$$

for gases in the upper chamber, and

$$|\alpha^- z^+\rangle\langle\alpha^- z^+| \mapsto |z^+ z^+\rangle\langle z^+ z^+|, \quad (35)$$

$$|\alpha^- z^-\rangle\langle\alpha^- z^-| \mapsto |z^+ z^-\rangle\langle z^+ z^-| \quad (36)$$

for the gases in the lower chamber. The successive elimination and reinsertion of the impermeable diaphragm yielded two chambers of equal volume  $V/2$  and same content, viz. the *mixture* of gases described by  $|z^+ z^+\rangle\langle z^+ z^+|$  and  $|z^+ z^-\rangle\langle z^+ z^-|$  (Fig. 6, e).

Tatiana's final rotation for the gas in the lower chamber,

$$|z^+ z^+\rangle \mapsto |x^+ z^+\rangle, \quad |z^+ z^-\rangle \mapsto |x^+ z^-\rangle, \quad (37)$$

only led to two equal chambers containing the *mixtures* of  $\frac{1}{2}|z^+ z^+\rangle\langle z^+ z^+| + \frac{1}{2}|z^+ z^-\rangle\langle z^+ z^-|$  and  $\frac{1}{2}|x^+ z^+\rangle\langle x^+ z^+| + \frac{1}{2}|x^+ z^-\rangle\langle x^+ z^-|$  gases respectively (Fig. 6, f).

From her point of view, i.e., from what her measuring means could tell, this final situation was identical with the initial one (Fig. 6, a), i.e. a  $z^+$ -gas in one chamber and an  $x^+$ -gas in the other, and so she thought the thermodynamic cycle completed. But we see now that the final and initial situations were in fact *different*. Hence the second law was *not* violated, because *the cycle was not completed*, and the form (3) for the second law *does not apply*.

It is also easy to see that in order to return to the initial condition an amount of work  $-Q''' \geq 4 \times (1/4)NkT \ln 2 \approx 0.693NkT$  has to be *spent* to separate the  $|z^+ z^+\rangle\langle z^+ z^+|$ -gas from the  $|z^+ z^-\rangle\langle z^+ z^-|$ -gas, and analogously for the  $|x^+ z^+\rangle\langle x^+ z^+|$ - and  $|x^+ z^-\rangle\langle x^+ z^-|$ -gases. A final operation must then be performed corresponding to the rotations of the density matrices  $|z^+ z^-\rangle\langle z^+ z^-|$  and  $|x^+ z^+\rangle\langle x^+ z^+|$  to  $|z^+ z^+\rangle\langle z^+ z^+|$  and  $|x^+ z^-\rangle\langle x^+ z^-|$  respectively, and we have finally reached again the initial condition (Fig. 6, a). The total amount of heat *absorbed* by the gases in this completing process would then be

$$Q = Q' + Q'' + Q''' \leq (0.693 - 0.416 - 0.693)NkT = -0.416NkT \leq 0, \quad (38)$$

and the second law, for the completed cycle, would be satisfied (strictly so: we see that the whole process is irreversible, and it is easy to check that the only irreversible step was Tatiana's transformation and separation into  $\alpha^+$ - and  $\alpha^-$ -gases).

The original conclusion has thus been reversed: no violation of the second law is found.

### 3. CONCLUSIONS

Preparation procedure and density matrix, with their respective properties, are quite different concepts, but intimately related because the latter is a mathematical representation of the former. In particular, the orthogonality of two density matrices *mathematically represents* the fact that their corresponding preparation procedures can be distinguished in one

shot. The one-shot distinguishability of two preparation procedures is also equivalent to the possibility of separating them by appropriate semi-permeable diaphragms. This equivalence is important because it relates their statistical and gross thermodynamic properties.

A consequence of this physical-mathematical relation is that an observer cannot assume the non-orthogonality of two density matrices and, at the same time, claim the one-shot distinguishability of their corresponding preparation procedures, because this assumption is self-contradictory and can only lead to vain conclusions. We have seen this kind of contradictory assumption behind the second statement (2).

However, *two* observers can represent the same preparations by means of density matrices having different numerical values and properties (e.g., orthogonality), and even different dimensionality. This may happen either because the two observers have different pieces of knowledge about the preparations' properties and the measurements available; or because each observer, having a different purpose or application, considers different sets of preparations and measurements to describe the same physical phenomenon. In particular, properties like one-shot distinguishability — and thus also orthogonality — always depend on the particular set of measurement procedures which an observer decides to consider (sometimes the whole known set at his or her disposal).

We have seen an example of this point in Peres' thought-experiment: An observer does not know of any measurement procedure that can distinguish in one shot two particular preparations; accordingly, she represents them by non-orthogonal density matrices. A second observer then shows the existence of such a measurement procedure, and so both observers *must* then use orthogonal density matrices to represent the preparations, at least when they want to operate with that measurement.

In any case, the consistency between the physical phenomena considered and their mathematical description is always essential.

### Acknowledgements

We thank an anonymous reviewer (see Footnote 18) for some constructive criticisms which helped to explain the ideas of this paper more clearly. PGLM thanks Louise for encouragement, suggestions, and invaluable odradek, and Peter Morgan for many useful comments. Special and affectionate thanks also to the staff of the Royal Institute of Technology's Library, for their irreplaceable work and ever prompt support. AM thanks Anders Karlsson for encouragement.

We dedicate this paper to the memory of Asher Peres and to his clarifying work in quantum mechanics.

### Appendix: ORTHOGONALITY PROOF

Suppose that two preparation procedures are represented by density matrices  $\phi$  and  $\psi$ , and that we have a measurement procedure represented by a POVM  $\{E_\mu, F_\nu\}$  such that

$$\begin{aligned} \text{tr}(\phi E_\mu) = 0 \quad \text{and} \quad \text{tr}(\psi E_\mu) \neq 0 \quad \text{for all } E_\mu, \\ \text{tr}(\psi F_\nu) = 0 \quad \text{and} \quad \text{tr}(\phi F_\nu) \neq 0 \quad \text{for all } F_\nu. \end{aligned} \quad (\text{A.1})$$

These equations mathematically represent the condition of one-shot distinguishability, as discussed in § 1.2.

We want to prove that from the above equations it follows that the two density matrices are orthogonal:

$$\text{tr}(\phi\psi) = 0. \quad (\text{A.2})$$

To prove this, let us consider the two-element POVM  $\{E, F\}$  given by:

$$E \stackrel{\text{def}}{=} \sum_{\mu} E_{\mu}, \quad F \stackrel{\text{def}}{=} \sum_{\nu} F_{\nu}. \quad (\text{A.3})$$

This POVM represents a “coarse graining” of the original measurement procedure, with some results grouped together. It is easy to see that it satisfies

$$\begin{aligned} \text{tr}(\phi E) = 0 \quad \text{and} \quad \text{tr}(\psi E) = 1 \neq 0, \\ \text{tr}(\psi F) = 0 \quad \text{and} \quad \text{tr}(\phi F) = 1 \neq 0. \end{aligned} \quad (\text{A.4})$$

The first POVM element  $E$  can be written as a sum of one-dimensional orthogonal projectors  $\{|i\rangle\langle i|\}$  (here and in the following the indices  $i, k, j$ , and  $l$  take values in appropriate and possibly distinct ranges):

$$E = \sum_i e_i |i\rangle\langle i|, \quad \text{with } 0 < e_i \leq 1 \text{ for all } i \quad (\text{A.5})$$

(note that the sum is not necessarily a convex combination, even though its coefficients are positive and not greater than unity).

We can decompose the first density matrix  $\phi$  in an analogous manner:

$$\phi = \sum_k \phi_k |\tilde{k}\rangle\langle \tilde{k}|, \quad \text{with } 0 < \phi_k \leq 1 \text{ for all } k \text{ and } \sum_k \phi_k = 1, \quad (\text{A.6})$$

where the projectors  $\{|\tilde{k}\rangle\langle \tilde{k}|\}$  are not necessarily parallel or orthogonal to the  $\{|i\rangle\langle i|\}$ .

The assumption  $\text{tr}(\phi E) = 0$  can be written as

$$\text{tr}(\phi E) = \sum_{k,i} \phi_k e_i |\langle \tilde{k} | i \rangle|^2 = 0, \quad (\text{A.7})$$

which by the strict positivity of the  $\phi_k$  and  $e_i$  implies

$$\langle \tilde{k} | i \rangle = 0, \quad \text{for all } k \text{ and } i, \quad (\text{A.8})$$

i.e., the projectors — equivalently, the eigenvectors — of the matrix  $E$  are in fact all orthogonal to those of the matrix  $\phi$ .

This means that the  $\{|i\rangle\langle i|\}$  can be completed by the  $\{|\tilde{k}\rangle\langle\tilde{k}|\}$  and some additional projectors  $\{|j'\rangle\langle j'|\}$  to form a complete set of orthonormal projectors — an orthonormal basis:

$$\{|i\rangle\langle i|, |\tilde{k}\rangle\langle\tilde{k}|, |j'\rangle\langle j'|\}_{ikj}. \quad (\text{A.9})$$

Writing the identity matrix  $\mathbf{I}$  in terms of the new projectors,

$$\mathbf{I} \equiv \sum_i |i\rangle\langle i| + \sum_k |\tilde{k}\rangle\langle\tilde{k}| + \sum_j |j'\rangle\langle j'|, \quad (\text{A.10})$$

we have that the second POVM element  $\mathbf{F}$  must be given by

$$\mathbf{F} = \mathbf{I} - \mathbf{E} = \sum_i (1 - e_i) |i\rangle\langle i| + \sum_k |\tilde{k}\rangle\langle\tilde{k}| + \sum_j |j'\rangle\langle j'|. \quad (\text{A.11})$$

Let us now decompose the second density matrix  $\psi$  as

$$\psi = \sum_l \psi_l |\hat{l}\rangle\langle\hat{l}|, \quad \text{with } 0 < \psi_l \leq 1 \text{ for all } l \text{ and } \sum_l \psi_l = 1, \quad (\text{A.12})$$

where the projectors  $\{|\hat{l}\rangle\langle\hat{l}|\}$  do not necessarily belong to the complete set previously introduced.

Using Eqns. (A.12) and (A.11), we rewrite the assumption that  $\text{tr}(\psi\mathbf{F}) = 0$  as

$$\begin{aligned} \text{tr}(\psi\mathbf{F}) &= \sum_{l,i} \psi_l (1 - e_i) |\langle\hat{l}|i\rangle|^2 + \\ &\sum_{l,k} \psi_l |\langle\hat{l}|\tilde{k}\rangle|^2 + \sum_{l,j} \psi_l |\langle\hat{l}|j'\rangle|^2 = 0. \end{aligned} \quad (\text{A.13})$$

Noting that all the sum terms are non-negative, and that the coefficients  $\psi_l$  are strictly positive, we deduce in particular that

$$\langle\hat{l}|\tilde{k}\rangle = 0, \quad \text{for all } l \text{ and } k, \quad (\text{A.14})$$

which means that the eigenvectors of the density matrix  $\phi$  are all orthogonal to those of the matrix  $\psi$ .

We have thus

$$\text{tr}(\phi\psi) = \sum_{k,l} \phi_k \psi_l |\langle\hat{l}|\tilde{k}\rangle|^2 = 0, \quad (\text{A.15})$$

Q.E.D.

The converse is also easy to demonstrate. Consider again the definitions (A.6) and (A.12), and assume that these density matrices are orthogonal, i.e., Eqn. (A.15). It follows that their eigenvectors are orthogonal, Eqn. (A.14), and may be used together with additional projectors  $\{|j'\rangle\langle j'|\}$  to form a complete orthonormal set

$$\{|\tilde{k}\rangle\langle\tilde{k}|, |\hat{l}\rangle\langle\hat{l}|, |j'\rangle\langle j'|\}_{k,l,j}. \quad (\text{A.16})$$

Now define the operators

$$\mathbf{E} \stackrel{\text{def}}{=} \sum_k |\tilde{k}\rangle\langle\tilde{k}|, \quad (\text{A.17})$$

$$\mathbf{F} \stackrel{\text{def}}{=} \mathbf{I} - \mathbf{E} = \sum_l |\hat{l}\rangle\langle\hat{l}| + \sum_j |j'\rangle\langle j'| \quad (\text{A.18})$$

(they are *not* those used in the previous proof, although we use the same symbols for convenience). These operators form, as is easily checked, a POVM  $\{\mathbf{E}, \mathbf{F}\}$ , which satisfy Eqns. (A.4). If we moreover assume that any POVM may be physically realised by some measurement procedure,<sup>28</sup> then we have proven the converse statement: if two preparations are represented by orthogonal density matrices, it means that they are one-shot distinguishable. Q.E.D.

- 
- [1] J. von Neumann, *Mathematische Grundlagen der Quantenmechanik* (Springer-Verlag, Berlin, 1996), 2nd ed., first publ. 1932, transl. by Robert T. Beyer as *Mathematical Foundations of Quantum Mechanics* (Princeton University Press, Princeton, 1955).
  - [2] J. von Neumann, *Thermodynamik quantenmechanischer Gesamtheiten*, Gött. Nach. pp. 273–291 (1927), repr. in *John von Neumann: Collected Works. Vol. I: Logic, theory of sets and quantum mechanics* (Pergamon Press, Oxford, 1961), ed. by A. H. Taub, pp. 236–254.
  - [3] A. Peres, *Quantum Theory: Concepts and Methods* (Kluwer Academic Publishers, Dordrecht, 1995).
  - [4] E. C. Kemble, *Fluctuations, thermodynamic equilibrium and entropy*, Phys. Rev. **56**, 1013–1023 (1939).
  - [5] E. C. Kemble, *The quantum-mechanical basis of statistical mechanics*, Phys. Rev. **56**, 1146–1164 (1939).
  - [6] E. T. Jaynes, *Where do we stand on maximum entropy?*, in R. D. Levine and M. Tribus, eds., *The Maximum Entropy Formalism* (The MIT Press, Cambridge (USA), p. 15, <http://bayes.wustl.edu/etj/node1.html>).
  - [7] E. T. Jaynes, *Inferential scattering* (1993), <http://bayes.wustl.edu/etj/node1.html>; “extensively rewritten” version of *Generalized scattering*, in C. R. Smith and W. T. Grandy, Jr., eds., *Maximum-Entropy and Bayesian Methods in Inverse Problems* (D. Reidel Publishing Company, Dordrecht, 1985), p. 377.
  - [8] E. T. Jaynes, *Clearing up mysteries — the original goal*, in *Maximum Entropy and Bayesian Methods*, edited by J. Skilling (Kluwer Academic Publishers, Dordrecht, 1989), pp. 1–27, <http://bayes.wustl.edu/etj/node1.html>.
  - [9] E. T. Jaynes, *Probability in quantum theory*, in W. H. Zurek, ed., *Complexity, Entropy, and the Physics of Information* (Addison-Wesley, 1990), p. 381; revised and extended version at <http://bayes.wustl.edu/etj/node1.html>.
  - [10] E. T. Jaynes, *Probability Theory: The Logic of Science* (Cambridge University Press, Cambridge, 2003), ed. by G. Larry Bretthorst, first publ. 1995 at <http://bayes.wustl.edu/etj> (chapter 30, *Maximum entropy: matrix formulation*, of the original version of the book, not included in the printed one, is available at <http://www.imit.kth.se/~mana/work/cc30e.pdf>).
  - [11] C. A. Fuchs, *Quantum foundations in the light of quantum information* (2001), arxiv eprint [quant-ph/0106166](https://arxiv.org/abs/quant-ph/0106166).
  - [12] C. A. Fuchs and R. Schack, *Unknown quantum states and operations, a Bayesian view* (2004), arxiv eprint [quant-ph/0404156](https://arxiv.org/abs/quant-ph/0404156).

<sup>28</sup> See, however, Footnote 7.

- [13] T. A. Brun, J. Finkelstein, and N. D. Mermin, *How much state assignments can differ*, Phys. Rev. A **65**, 032315 (2002), arxiv eprint quant-ph/0109041.
- [14] C. M. Caves, C. A. Fuchs, and R. Schack, *Conditions for compatibility of quantum-state assignments*, Phys. Rev. A **66**, 062111 (2002), arxiv eprint quant-ph/0206110.
- [15] C. M. Caves, C. A. Fuchs, and R. Schack, *Quantum probabilities as Bayesian probabilities*, Phys. Rev. A **65**, 022305 (2002), arxiv eprint quant-ph/0106133.
- [16] P. G. L. Mana, *Why can states and measurement outcomes be represented as vectors?* (2003), arxiv eprint quant-ph/0305117.
- [17] P. G. L. Mana, *Probability tables*, arxiv eprint quant-ph/0403084, repr. in A. Y. Khrennikov, ed., *Quantum Theory: Reconsideration of Foundations — 2* (Vaxjö University Press, Vaxjö, Sweden, 2004), pp. 387–401.
- [18] P. G. L. Mana, (2005), in preparation.
- [19] L. Hardy, *Quantum theory from five reasonable axioms* (2001), arxiv eprint quant-ph/0101012.
- [20] E. T. Jaynes, *The Gibbs paradox*, in *Maximum-Entropy and Bayesian Methods*, edited by C. R. Smith, G. J. Erickson, and P. O. Neudorfer (Kluwer Academic Publishers, Dordrecht, 1992), pp. 1–22, <http://bayes.wustl.edu/etj/articles/gibbs.paradox.pdf>.
- [21] C. A. Truesdell, III, *Rational Thermodynamics* (Springer-Verlag, New York, 1984), 2nd ed., first publ. 1969.
- [22] I. Samohýl, *Thermodynamics of Irreversible Processes in Fluid Mixtures (Approached by Rational Thermodynamics)* (BSB B. G. Teubner Verlagsgesellschaft, Leipzig, 1987).
- [23] M. Šilhavý, *The Mechanics and Thermodynamics of Continuous Media* (Springer-Verlag, Berlin, 1997).
- [24] C. A. Truesdell, III and W. Noll, *The Non-Linear Field Theories of Mechanics* (Springer-Verlag, Berlin, 1992), 2nd ed., first publ. 1965.
- [25] W. Noll, *A new mathematical theory of simple materials*, Arch. Rational Mech. Anal. **48**, 1–50 (1972).
- [26] W. Noll, *5 Contributions to Natural Philosophy* (2004), <http://www.math.cmu.edu/~nw0z/publications/04-CNA-018/018.html>, pp. 67–363.
- [27] J. C. Willems, *Dissipative dynamical systems: Part I: General theory*, Arch. Rational Mech. Anal. **45**, 321–351 (1972), see also J. C. Willems, *Dissipative dynamical systems: Part II: Linear systems with quadratic supply rates*, Arch. Rational Mech. Anal. **45**, 352–393 (1972).
- [28] B. D. Coleman and D. R. Owen, *A mathematical foundation for thermodynamics*, Arch. Rational Mech. Anal. **54**, 1–104 (1974).
- [29] B. D. Coleman and D. R. Owen, *On thermodynamics and elastic-plastic materials*, Arch. Rational Mech. Anal. **59**, 25–51 (1975).
- [30] B. D. Coleman and D. R. Owen, *On the thermodynamics of semi-systems with restrictions on the accessibility of states*, Arch. Rational Mech. Anal. **66**, 173–181 (1977).
- [31] B. D. Coleman and D. R. Owen, *On the thermodynamics of elastic-plastic materials with temperature-dependent moduli and yield stresses*, Arch. Rational Mech. Anal. **70**, 339–354 (1979).
- [32] G. Del Piero, *A mathematical characterization of plastic phenomena in the context of Noll’s new theory of simple materials*, Eng. Fract. Mech. **21**, 633–639 (1985).
- [33] G. Del Piero and L. Deseri, *On the concepts of state and free energy in linear viscoelasticity*, Arch. Rational Mech. Anal. **138**, 1–35 (1997).
- [34] J. Serrin, *Conceptual analysis of the second law of thermodynamics*, Arch. Rational Mech. Anal. **70**, 355–371 (1979).
- [35] L. Carroll, (Rev. Charles Lutwidge Dodgson), *Through the Looking-Glass, and What Alice Found There* (1871), repr. in *The Annotated Alice* (Penguin Books, London, 1970), ed. by Martin Gardner.
- [36] H. Ekstein, *Presymmetry*, Phys. Rev. **153**, 1397–1402 (1967).
- [37] H. Ekstein, *Presymmetry. II*, Phys. Rev. **184**, 1315–1337 (1969).
- [38] R. Giles, *Foundations for quantum statistics*, J. Math. Phys. **9**, 357–371 (1968).
- [39] R. Giles, *Foundations for quantum mechanics*, J. Math. Phys. **11**, 2139–2160 (1970).
- [40] R. Giles, *Formal languages and the foundations of physics*, in C. A. Hooker, ed., *Physical Theory as Logico-Operational Structure* (D. Reidel Publishing Company, Dordrecht, 1979), pp. 19–87.
- [41] D. J. Foulis and C. H. Randall, *Operational statistics. I. Basic concepts*, J. Math. Phys. **13**, 1667–1675 (1972).
- [42] D. J. Foulis and C. H. Randall, *Manuals, morphisms and quantum mechanics*, in Marlow [114] (1978), pp. 105–126.
- [43] C. H. Randall and D. J. Foulis, *Operational statistics. II. Manuals of operations and their logics*, J. Math. Phys. **14**, 1472–1480 (1973).
- [44] J. L. Park and W. Band, *Mutually exclusive and exhaustive quantum states*, Found. Phys. **6**, 157–172 (1976).
- [45] W. Band and J. L. Park, *New information-theoretic foundations for quantum statistics*, Found. Phys. **6**, 249–262 (1976).
- [46] A. Peres, *What is a state vector?*, Am. J. Phys. **52**, 644–650 (1984).
- [47] A. Peres, *When is a quantum measurement?*, Am. J. Phys. **54**, 688–692 (1986).
- [48] L. E. Ballentine, *The statistical interpretation of quantum mechanics*, Rev. Mod. Phys. **42**, 358 (1970).
- [49] H. P. Stapp, *S-matrix interpretation of quantum theory*, Phys. Rev. D **3**, 1303 (1971).
- [50] H. P. Stapp, *The Copenhagen interpretation*, Am. J. Phys. **40**, 1098 (1972).
- [51] A. Peres, *Pure states, mixtures and compounds*, in Marlow [114] (1978), pp. 67–363.
- [52] K. Kraus, *States, Effects, and Operations: Fundamental Notions of Quantum Theory* (Springer-Verlag, Berlin, 1983).
- [53] A. Komar, *Indeterminate character of the reduction of the wave packet in quantum theory*, Phys. Rev. **126**, 365 (1962).
- [54] E. P. Wigner, *On the quantum correction for thermodynamic equilibrium*, Phys. Rev. **40**, 749–759 (1932).
- [55] U. Fano, *Description of states in quantum mechanics by density matrix and operator techniques*, Rev. Mod. Phys. **29**, 74–93 (1957).
- [56] K. Kraus, *General state changes in quantum theory*, Ann. of Phys. **64**, 311–335 (1971).
- [57] E. B. Davies, *Quantum Theory of Open Systems* (Academic Press, London, 1983).
- [58] A. Peres, *Classical interventions in quantum systems. I. The measuring process*, Phys. Rev. A **61**, 022116 (2000), arxiv eprint quant-ph/9906023.
- [59] M.-D. Choi, *Completely positive linear maps on complex matrices*, Lin. Alg. Appl. **10**, 285–290 (1975).
- [60] G. Ghirardi, A. Rimini, and T. Weber, *Is the density matrix description of statistical ensembles exhaustive?*, Nuovo Cimento B **29**, 135–158 (1975).
- [61] O. Cohen, *Counterfactual entanglement and nonlocal correlations in separable states*, Phys. Rev. A **60**, 80–84 (1999), arxiv eprint quant-ph/9907109. Cohen’s confusion is explained and corrected by D. R. Terno, *Comment on “Counterfactual entanglement and nonlocal correlations in separable*



- able states”, Phys. Rev. A **63**, 016101 (2001), arxiv eprint quant-ph/9912002. See also Cohen’s reply, *Reply to “Comment on ‘Counterfactual entanglement and nonlocal correlations in separable states’*”, Phys. Rev. A **63**, 016102 (2001), arxiv eprint quant-ph/0008080.
- [62] G.-L. Long, Y.-F. Zhou, J.-Q. Jin, and Y. Sun, *Distinctness of ensembles having the same density matrix and the nature of liquid NMR quantum computing* (2004), arxiv eprint quant-ph/0408079.
- [63] L. P. Hughston, R. Jozsa, and W. K. Wootters, *A complete classification of quantum ensembles having a given density matrix*, Phys. Lett. A **183**, 14–18 (1993).
- [64] A. Hobson, *Concepts in Statistical Mechanics* (Gordon and Breach Science Publishers, New York, 1971).
- [65] W. K. Wootters, *Statistical distance and Hilbert space*, Phys. Rev. D **23**, 357 (1981).
- [66] W. K. Wootters and B. D. Fields, *Optimal state-determination by mutually unbiased measurements*, Ann. of Phys. **191**, 363–381 (1989).
- [67] A. Peres and W. K. Wootters, *Optimal detection of quantum information*, Phys. Rev. Lett. **66**, 1119 (1991).
- [68] K. R. W. Jones, *Principles of quantum inference*, Ann. of Phys. **207**, 140–170 (1991).
- [69] K. R. W. Jones, *Fundamental limits upon the measurement of state vectors*, Phys. Rev. A **50**, 3682–3699 (1994).
- [70] S. L. Braunstein and C. M. Caves, *Statistical distance and the geometry of quantum states*, Phys. Rev. Lett. **72**, 3439 (1994).
- [71] P. B. Slater, *Reformulation for arbitrary mixed states of Jones’ Bayes estimation of pure states*, Physica A **214**, 584–604 (1995).
- [72] R. D. Gill and S. Massar, *State estimation for large ensembles*, Phys. Rev. A **61**, 042312 (2000), arxiv eprint quant-ph/9902063.
- [73] C. A. Truesdell, III and S. Bharatha, *The Concepts and Logic of Classical Thermodynamics as a Theory of Heat Engines: Rigorously Constructed upon the Foundation Laid by S. Carnot and F. Reech* (Springer-Verlag, New York, 1977).
- [74] M. Planck, *Treatise on Thermodynamics* (Dover Publications, New York, 1945), 3rd ed., transl. from the seventh German edition by A. Ogg, first publ. 1897.
- [75] G. N. Lewis and M. Randall, *Thermodynamics and the Free Energy of Chemical Substances* (McGraw-Hill Book Company, New York, 1923).
- [76] J. R. Partington, *An Advanced Treatise on Physical Chemistry. Vol. I: Fundamental Principles. The Properties of Gases* (Longmans, Green and Co, London, 1949).
- [77] H. B. Callen, *Thermodynamics and an Introduction to Thermostatistics* (John Wiley & Sons, New York, 1985), 2nd ed., first publ. 1960.
- [78] H. A. Buchdahl, *The Concepts of Classical Thermodynamics* (Cambridge University Press, London, 1966).
- [79] J. W. Gibbs, *On the equilibrium of heterogeneous substances*, Trans. Connect. Acad. **3**, 108–248, 343–524 (1876–1878), repr. in *The Collected Works of J. Willard Gibbs. Vol. 1: Thermodynamics* (Yale University Press, New Haven, 1948), first publ. 1906, pp. 55–353.
- [80] C. A. Truesdell, III and R. A. Toupin, *The Classical Field Theories*, in S. Flügge, ed., *Handbuch der Physik: Band III/1: Prinzipien der klassischen Mechanik und Feldtheorie [Encyclopedia of Physics: Vol. III/1: Principles of Classical Mechanics and Field Theory]* (Springer-Verlag, Berlin, 1960), pp. 226–858.
- [81] R. M. Bowen, *Thermochemistry of reacting materials*, J. Chem. Phys. **49**, 1625–1637 (1968).
- [82] C. A. Truesdell, III, *Sulle basi della termodinamica delle miscele*, Atti Accad. Naz. Lincei: Rend. Sc. fis. mat. nat. **44**, 381–383 (1968).
- [83] I. Samohýl, *Thermodynamics of reacting mixtures of any symmetry with heat conduction, diffusion and viscosity*, Arch. Rational Mech. Anal. **147**, 1–45 (1999).
- [84] I. Müller, *A thermodynamic theory of mixtures of fluids*, Arch. Rational Mech. Anal. **28**, 1–39 (1968).
- [85] R. M. Bowen and D. J. Garcia, *On the thermodynamics of mixtures with several temperatures*, Int. J. Engng. Sci. **8**, 63–83 (1970).
- [86] R. J. Atkin and R. E. Craine, *Continuum theories of mixtures: basic theory and historical development*, Q. J. Mech. Appl. Math. **29**, 209–244 (1976).
- [87] R. J. Atkin and R. E. Craine, *Continuum theories of mixtures: applications*, J. Inst. Maths. Applics **17**, 153–207 (1976).
- [88] R. Fosdick and J. Patiño, *On the Gibbsian thermostatics of mixtures*, Arch. Rational Mech. Anal. **93**, 203–221 (1986), repr. in B. D. Coleman, M. Feinberg, and J. Serrin, eds., *Analysis and Thermomechanics: A Collection of Papers Dedicated to W. Noll* (Springer-Verlag, Berlin, 1987), pp. 435–453.
- [89] P. Ehrenfest and V. Trkal, *Deduction of the dissociation-equilibrium from the theory of quanta and a calculation of the chemical constant based on this*, Proc. Acad. Sci. Amsterdam (Proc. of the Section of Sciences Koninklijke Nederlandse Akademie van Wetenschappen) **23**, 162–183 (1920), repr. in P. Ehrenfest, *Collected Scientific Papers* (North-Holland Publishing Company, Amsterdam, 1959), ed. by Martin J. Klein, pp. 414–435.
- [90] D. Dieks and V. van Dijk, *Another look at the quantum mechanical entropy of mixing*, Am. J. Phys. **56**, 430–434 (1988).
- [91] A. Einstein, *Beiträge zur Quantentheorie*, Ver. Deut. Phys. Ges. **16**, 820–828 (1914), transl. as *Contributions to quantum theory* in A. Einstein, *The Collected Papers of Albert Einstein: Vol. 6: The Berlin Years: Writings, 1914–1917. (English translation)* (Princeton University Press, Princeton, 1997), transl. by A. Engel and E. Schucking, pp. 20–26.
- [92] J. Larmor, *A dynamical theory of the electric and luminiferous medium. — Part III. Relations with material media*, Phil. Trans. R. Soc. Lond. A **190**, 205–300, 493 (1897), repr. in J. Larmor, *Mathematical and Physical Papers. Vol. II* (Cambridge University Press, Cambridge, 1929).
- [93] P. G. L. Mana, A. Månsson, and G. Björk (2005), in preparation.
- [94] I. M. Copi and C. Cohen, *Introduction to Logic* (MacMillan Publishing Company, New York, 1990), eighth ed., first publ. 1953.
- [95] I. M. Copi, *Symbolic Logic* (Macmillan Publishing, New York, 1979), 5th ed., first publ. 1954.
- [96] A. G. Hamilton, *Logic for Mathematicians* (Cambridge University Press, Cambridge, 1993), first publ. 1978.
- [97] R. Schack, T. A. Brun, and C. M. Caves, *Quantum Bayes rule*, Phys. Rev. A **64**, 014305 (2001), arxiv eprint quant-ph/0008113.
- [98] C. M. Caves, C. A. Fuchs, and R. Schack, *Unknown quantum states: the quantum de Finetti representation*, J. Math. Phys. **43**, 4537–4559 (2002), arxiv eprint quant-ph/0104088.
- [99] C. A. Fuchs, R. Schack, and P. F. Scudo, *De Finetti representation theorem for quantum-process tomography*, Phys. Rev. A **69**, 062305 (2004), arxiv eprint quant-ph/0307198.
- [100] B. de Finetti, *Foresight: Its logical laws, its subjective sources*, transl. with additional notes in H. E. Kyburg, Jr. and H. E. Smokler, eds., *Studies in Subjective Probability* (John Wiley & Sons, New York, 1964), pp. 93–158.

- [101] P. Pechukas, *Reduced dynamics need not be completely positive*, Phys. Rev. Lett. **73**, 1060–1062 (1994), see also R. Alicki, *Comment on “Reduced dynamics need not be completely positive”*, Phys. Rev. Lett. **75**, 3020 (1995), and P. Pechukas, *Pechukas replies*, Phys. Rev. Lett. **75**, 3021 (1995).
- [102] P. Štelmachovič and V. Bužek, *Dynamics of open quantum systems initially entangled with environment: Beyond the Kraus representation*, Phys. Rev. A **64**, 062106 (2001), arxiv eprint [quant-ph/0108136](http://arxiv.org/abs/quant-ph/0108136), see also *Erratum: Dynamics of open quantum systems initially entangled with environment: Beyond the Kraus representation*, Phys. Rev. A **67**, 029902 (2003).
- [103] H. Hayashi, G. Kimura, and Y. Ota, *Kraus representation in the presence of initial correlations*, Phys. Rev. A **67**, 062109 (2003), arxiv eprint [quant-ph/0303061](http://arxiv.org/abs/quant-ph/0303061).
- [104] K. M. Fonseca Romero, P. Talkner, and P. Hänggi, *Is the dynamics of open quantum systems always linear?*, Phys. Rev. A **69**, 052109 (2004), arxiv eprint [quant-ph/0311077](http://arxiv.org/abs/quant-ph/0311077).
- [105] T. F. Jordan, A. Shaji, and E. C. G. Sudarshan, *Dynamics of initially entangled open quantum systems* (2004), arxiv eprint [quant-ph/0407083](http://arxiv.org/abs/quant-ph/0407083).
- [106] T. F. Jordan, A. Shaji, and E. C. G. Sudarshan, *The Schrödinger picture for open quantum dynamics* (2005), arxiv eprint [quant-ph/0505123](http://arxiv.org/abs/quant-ph/0505123).
- [107] T. F. Jordan, *Affine maps of density matrices*, Phys. Rev. A **71**, 034101 (2005), arxiv eprint [quant-ph/0407203](http://arxiv.org/abs/quant-ph/0407203).
- [108] H. Grad, *The many faces of entropy*, Comm. Pure Appl. Math. **14**, 323–354 (1961).
- [109] A. S. Holevo, *Probabilistic and Statistical Aspects of Quantum Theory* (North-Holland, Amsterdam, 1982), first publ. in Russian 1980.
- [110] H. Grad, *Statistical mechanics of dynamical systems with integrals other than energy*, J. Phys. Chem. **56**, 1039–1048 (1952).
- [111] H. Grad, *Levels of description in statistical mechanics and thermodynamics*, in M. Bunge, ed., *Delaware Seminar in the Foundations of Physics* (Springer-Verlag, Berlin, 1967), pp. 49–76.
- [112] L. C. Woods, *The Thermodynamics of Fluid Systems* (Oxford University Press, London, 1975).
- [113] E. T. Jaynes, *Thermodynamics* (1965 ca.), <http://bayes.wustl.edu/etj/node2.html>.
- [114] A. R. Marlow, ed., *Mathematical Foundations of Quantum Theory* (Academic Press, London, 1978).

(Note: ‘arxiv eprints’ are located at <http://arxiv.org/>.)