

Full Research Paper

A Sensitive Chemiluminescence Method for Determination of Hydroquinone and Catechol

Lijun Zhao¹, Baoqiang Lv², Hongyan Yuan², Zaide Zhou¹ and Dan Xiao^{1,2*}

¹ College of chemistry, Sichuan University, Chengdu, 610064, P. R. China

² College of chemical engineering, Sichuan University, Chengdu, 610064, P. R. China

* Author to whom correspondence should be addressed; Fax +86 28 85407859; Tel. +86 28 85407958; E-mail: xiaodan@scu.edu.cn

Received: 14 March 2007 / Accepted: 19 April 2007 / Published: 26 April 2007

Abstract: A novel flow-injection chemiluminescence (CL) method has been developed for the determination of hydroquinone (HQ) and catechol (CT), based on their inhibition of the chemiluminescence reaction of luminol–KMnO₄–β-cyclodextrin (β-CD). It was found that β-cyclodextrin could effectively enhance the chemiluminescence produced from the reaction of luminol with KMnO₄ in basic media. The proposed method is simple, rapid, convenient and sensitive, has a linear range of 1–20 ng/mL for catechol with a detection limit of 0.4 ng/mL, and 1–10 ng/mL for hydroquinone with a detection limit of 0.1 ng/mL, respectively. The possible mechanism of the CL reaction is also discussed.

Keywords: hydroquinone; catechol; chemiluminescence; flow injection analysis; determination

1. Introduction

Hydroquinone and catechol are phenolic compounds and are widely used in tanning, cosmetics, the pharmaceutical industry and in developing photo-graphs and thus are important environmental pollutants [1, 2]. It is also well documented that HQ and CT are among the most abundant organic constituents of mainstream tobacco smoke [3-5]. These compounds are harmful to humans and animals even in very low concentration. Therefore, it is very important to develop a highly sensitive and selective analytical method for the determination of hydroquinone and catechol in food, biological and

environmental monitoring, etc. From the literature, several methods for the determination of hydroquinone and catechol are available, such as spectrophotometry [6,7], high performance liquid chromatography (HPLC) [2,8] and electrochemiluminescence [9] techniques. To explore an alternative method for the determination of hydroquinone and catechol, chemiluminescence coupled with flow injection system is developed.

Chemiluminescence (CL) is a high sensitive analytical technique that can be used in the determination of different compounds in various fields. In recent years, it has received much attention, especially with flow injection (FIA), due to its high sensitivity, wide linear range and simple instrumentation [10-17]. And some CL methods have been developed for the detection of hydroquinone and catechol [10,17,18]. He et al. [10] have proposed a CL method based on the enhancing effect of polyhydroxy phenols on the Fe^{3+} - H_2O_2 -Rh6G system. Du et al. [17] have developed another method for determination of pyrogallol, phloroglucinol, hydroquinone and resorcinol based on the ferricyanide/ferrocyanide-enhanced luminol-polyphenol CL.

In our work, we found that chemiluminescence generated by the reaction of luminol with KMnO_4 in basic media could be significantly enhanced by β -CD. While the enhanced chemiluminescence was strongly inhibited in the presence of hydroquinone and catechol. Based on these observations, a new flow-injection CL method was proposed for the determination of hydroquinone and catechol, with detection limits of 0.1 ng/mL and 0.4 ng/mL, respectively. However, the proposed CL system was not suitable for the determination of dihydroxybenzene isomer-resorcinol. The peak of the CL became distorted irregularly for resorcinol, probably because the resorcinol could not be oxidized by singlet oxygen and hydroxyl radical formed in the reaction to produce corresponding quinone. Moreover, the presence of resorcinol affected the detection of hydroquinone and catechol. The actual effect of resorcinol on the CL reaction is still unknown, further study is being carried out. A possible mechanism of the CL reaction was also discussed.

2. Experimental

2.1. Reagents

All the chemicals were of analytical-reagent grade and were used as received. The double-distilled water was used throughout. The 1.0 mg/mL standard solutions of hydroquinone and catechol were freshly prepared by dissolving appropriate amount of each in water. A 0.01 mol/L luminol stock solution was prepared with 100mL of 0.1 mol/L NaOH solution. A 0.01 mol/L KMnO_4 stock solution was prepared with double-distilled water. β -cyclodextrin (1.0×10^{-3} mol/L) stock standard solution was prepared by dissolving appropriate amount in 0.04 mol/L NaOH solution. These standard solutions were stored in the refrigerator and protected from light.

2.2. Apparatus

The flow-injection system used in this work is shown in Fig. 1. Two peristaltic pumps were used to deliver all solutions. PTFE tube (0.8 mm i.d.) was used to connect all components in the flow system. The streams of luminol, KMnO_4 , β -cyclodextrin and analyte were mixed in a flow cell. The CL signal

produced in the flow cell was detected with a photomultiplier tube and recorded by an IBM-compatible computer using flow-injection CL analysis system (Xi'an Ruike Electronic Equipment Corporation, China). A model F-4500 fluorescence spectrophotometer (Hitachi, Japan) and a model UV-2300 spectrophotometer (Shanghai, China) were also used.

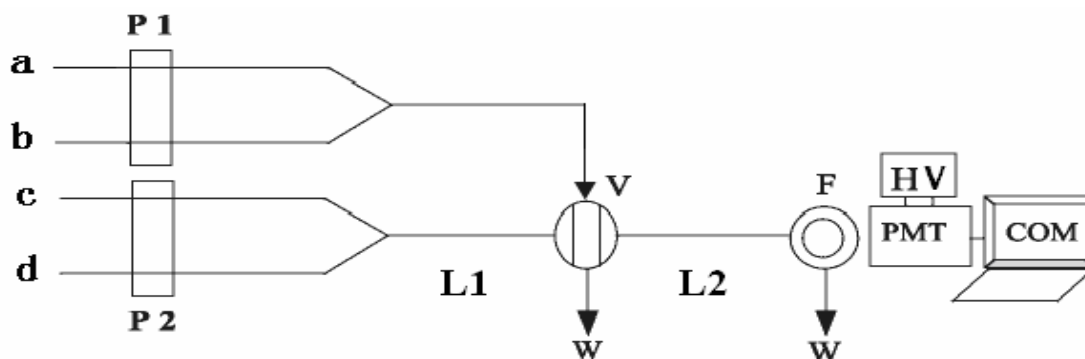

Figure 1. Schematic of the flow system for determination of hydroquinone and catechol. a, KMnO_4 solution; b, β -cyclodextrin solution; c, sample solution; d, luminol solution; P1 and P2, peristaltic pumps 1 and 2; L2 450 mm length; V, eight-way injection valve; F, flow cell; PMT, photomultiplier tube; HV, high voltage (operated at -600 V); COM, computer; W, waste solution.

2.3. Procedures

As shown in Fig. 1, flow lines a–d, were inserted into KMnO_4 solution, β -CD solution, sample solution and luminol solution, respectively. The mixture of KMnO_4 and β -CD was merged through the eight-way injection valve into the mixture of sample solution and luminol solution. Then the mixed solution was pumped continuously into the flow cell located in front of the detection window of the photomultiplier tube (PMT). The CL emission was converted to current signal by PMT and the output was fed to luminescence analyzer, recorded with a computer via supplied software (REMEX CL Analysis System V 2.12). The concentration of sample solution was quantified by the relative CL intensity (ΔI).

3. Results and Discussions

3.1. The CL Characteristics of the Reaction System

As shown in Fig. 2, the CL intensity reached a maximum in the absence of sample solution. With the injection of sample solution, a decreased CL signal appeared, and the CL intensity varied with concentration of sample solution. Therefore, the proposed CL system was suitable for detecting hydroquinone and catechol. To obtain the highest CL signal/noise, the flow rate of peristaltic pumps was also tested. The flow rate of pump 1 and 2 were all finally set at 30 turns/min as a suitable condition with superior sensitivity and reagent consumption. Six nanogram per milliliter hydroquinone solution was used to optimize the experimental conditions.

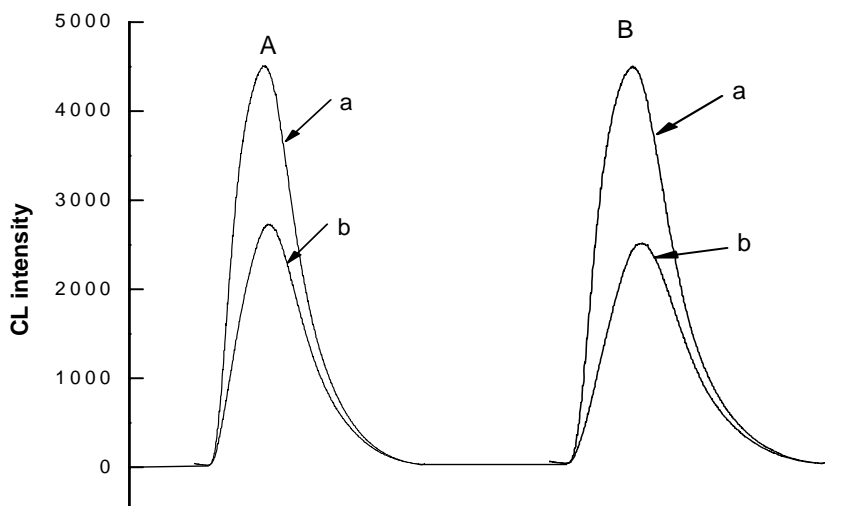

Figure 2. The CL characteristics of the reaction system. A. a, Blank: 1.0×10^{-5} mol/L $\text{KMnO}_4 + 1.0 \times 10^{-4}$ mol/L β -cyclodextrin + 1.0×10^{-4} mol/L luminol; b, a + 10 ng/mL hydroquinone; B. a, Blank: 1.0×10^{-5} mol/L $\text{KMnO}_4 + 1.0 \times 10^{-4}$ mol/L β -cyclodextrin + 1.0×10^{-4} mol/L luminol; b, a + 10 ng/mL catechol.

3.2. Effect of β -CD and NaOH Concentrations

Due to a significant effect of the concentration of NaOH medium on the CL system, five different concentration solutions, i.e. 0.02 mol/L, 0.04 mol/L, 0.06 mol/L, 0.08 mol/L, 0.1 mol/L NaOH were tested. As shown in Fig. 3, the CL intensity was dramatically increased with the increase of NaOH concentration and the highest CL signal/noise was obtained in the 0.04 mol/L NaOH, above which the baseline of the system became higher. Therefore, 0.04 mol/L NaOH solution was selected for subsequent experiments. The concentration of β -CD was an important factor, because it was used as an enhancer in the reaction. The influence of β -CD concentration on CL intensity was initially examined from 1.0×10^{-6} to 4.0×10^{-4} mol/L (Fig. 4). The result indicated that 1.0×10^{-4} mol/L β -CD gave the highest relative CL intensity and the sensitivity decreased on either side of this value. Therefore, 1.0×10^{-4} mol/L β -CD was chosen for the subsequent studies.

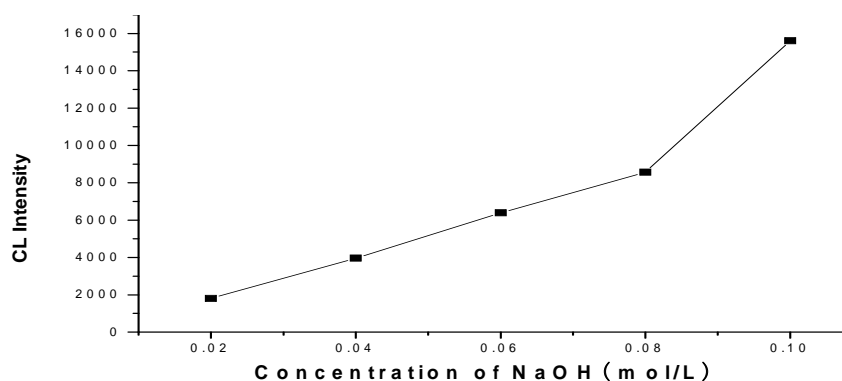

Figure 3. Effect of NaOH concentration on CL intensity (sample = 6 ng/mL).

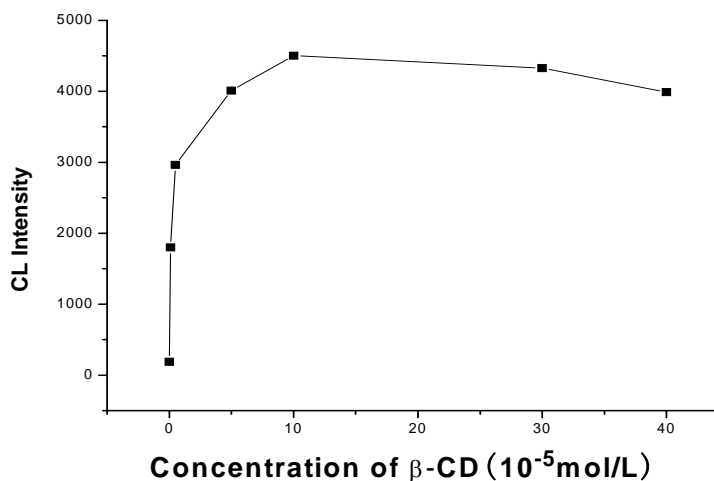

Figure 4. Effect of β -CD concentration on CL intensity (sample = 6 ng/mL).

3.3. Effect of Luminol Concentration

Luminol was not only the reducing agent for the reduction of KMnO_4 , but also the CL agent in the system. Hence, its concentration should be carefully optimized to ensure that the system was in good stability. The effect of luminol concentration was studied in the range 1.0×10^{-5} to 0.6×10^{-3} mol/L (Fig. 5). It was found that the CL intensity was significantly increased with the increase of luminol concentration below 1.0×10^{-4} mol/L, above which the background signal was also enhanced, leading to the decrease of signal/noise ratio. Thus, 1.0×10^{-4} mol/L luminol was selected for subsequent work.

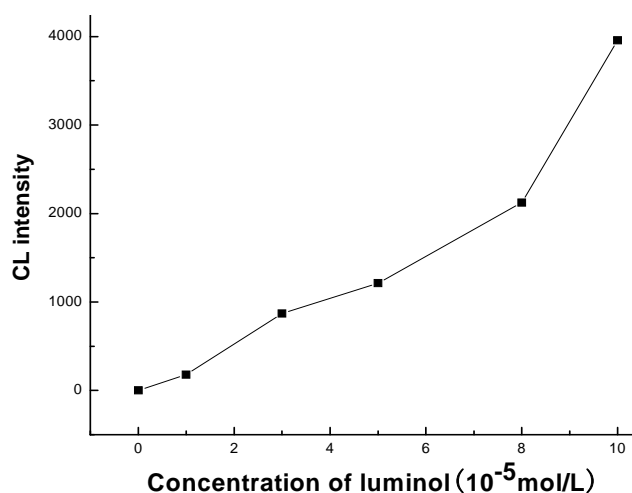

Figure 5. Effect of luminol concentration on CL intensity (sample = 6 ng/mL).

3.4. Effect of KMnO_4 Concentration

The influence of KMnO_4 at different concentrations from 0.1×10^{-4} to 3.0×10^{-4} mol/L were tested (Fig. 6). The peak height increased gradually with raising KMnO_4 concentration up to 0.5×10^{-4} mol/L, above which CL intensity decreased sharply probably because of self-absorption of the KMnO_4 . It was

found that the stability of the CL signal fluctuated obviously as the concentration of KMnO_4 became 0.5×10^{-4} mol/L and 0.2×10^{-4} mol/L. Therefore, 1.0×10^{-5} mol/L KMnO_4 was used for the following studies.

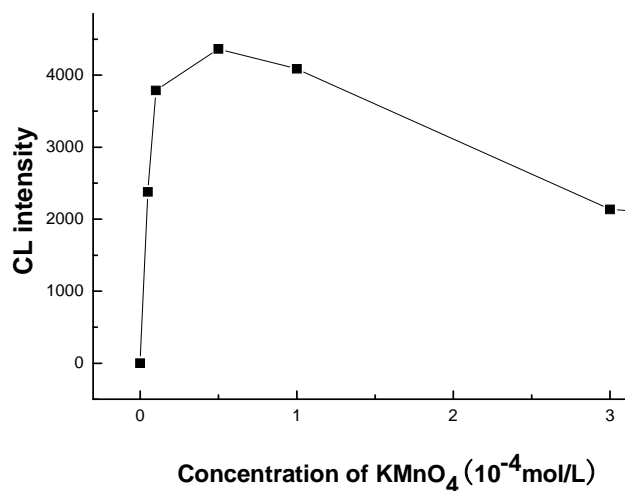

Figure 6. Effect of KMnO_4 concentration on CL intensity (sample = 6 ng/mL).

3.5. Calibration Curves and Detection Limits

Under the optimum conditions described, the calibration curves were obtained for hydroquinone and catechol by plotting the graph of ΔI (relative CL intensity) vs. concentration. The measurable range of hydroquinone concentration was 1–10 ng/mL with a regression equation of $\Delta I = 187.49C + 194.97$ (C, ng/mL; $r = 0.9942$) and the detection limit was 0.1 ng/mL. A series of 13 repetitive measurements of 6 ng/mL hydroquinone yielded a relative standard deviation of 1.1%. The system had a linear respond to catechol concentration in the range 1–20 ng/mL with a detection limit of 0.4 ng/mL and the regression equation was $\Delta I = 190.09C + 296.69$ (C, ng/mL; $r = 0.9939$). The relative standard deviation for 6 ng/mL catechol was 1.6% ($n = 13$).

3.6 Interference studies

The influence of some common foreign species on the determination of 6 ng/mL hydroquinone was studied under the optimum experimental conditions stated above. The tolerable limit of a foreign species was taken as a relative error not greater than $\pm 5\%$ in the CL signal of hydroquinone. No interference has been found when including up to 1000-fold Na^+ , K^+ , SO_4^{2-} , NO_3^- , Cl^- , Br^- , CO_3^{2-} , Ac^- , NH_4^+ ; 500-fold PO_4^{3-} , $\text{C}_2\text{O}_4^{2-}$, Ca^{2+} , SO_3^{2-} , Al^{3+} , ethanol; 100-fold Mg^{2+} , Zn^{2+} , Ni^{2+} , NO_2^- ; five-fold S^{2-} , Cu^{2+} , Hg^{2+} , Fe^{3+} , and equal amount of resorcinol and catechol. Metal ions can be eliminated by EDTA [19] and an exchange resin [10].

3.7 Analytical applications

Because of the interference, the proposed method can only determine the hydroquinone or catechol concentration individually. When the system was used for industrial wastewater, the sample should be

separated in advance. When the samples were river water and fishpond water, the mentioned substances were eliminated by filtration and ions were eliminated by adding an exchange resin [10]. In our work, the developed method was applied to the determination of catechol in river water. The determination results and recoveries are listed in Table 1. It can be seen that recovery varied from 96.0% to 107.0%, indicating that the method developed is suitable for determination of catechol. The system exhibited good stability and reproducibility, with relative standard deviation less than 3%. This is desirable for routine analysis.

Table 1. Determination of Catechol in River Water Samples.

Sample	Amount found (ng/mL) a (RSD)	Added (ng/mL)	Found (ng/mL) a	Recovery (%)
River water 1	15.62 (2.2)	1.0	16.58	96.0
		3.0	18.75	104.3
River water 2	15.78 (1.8)	1.0	16.85	107.0
		3.0	18.68	96.7

^a Average of three measurements.

3.8 Possible CL mechanism of the reaction

The possible mechanism of the reaction could be demonstrated in Scheme 1. CL is observed after mixing KMnO_4 and luminol in a basic solution, which is described in equation 1 [20]. The CL signal is greatly enhanced with the addition of β -CD. In order to explain the possible CL mechanism, the subsequent experiments were carried out with the sample solutions. Firstly, the spectra of CL reaction in the luminol– KMnO_4 – β -CD CL system in the presence and absence of sample solutions were measured by F-4500 fluorescence spectrophotometer, and compared with that of a conventional luminol– KMnO_4 reaction [21,22]. The results showed that the maximum wavelength of CL spectra was identical with that of reported before ($\sim 425\text{nm}$) [21,22]. It is suggested that the emission species is excited luminol. Secondly, the influence of dissolved oxygen on the CL reaction was investigated by purging solution with argon, the CL intensity was decreased by about 60%, this inferred that the dissolved oxygen possibly played a key role in this CL reaction [23]. Thirdly, the effect of ascorbic acid, a common scavenger of free radicals, on the system was studied to ascertain if free radical participated in the reaction. The striking quenching effect was obtained on the addition of ascorbic acid even at 1.0×10^{-5} mol/L level. The results indicated that free radical may be involved in the CL process (equation 2 and 3). Based on the above-described experimental results, we could conclude that the possible mechanism of the proposed system is a similar behavior as that described previously [10,23]. Singlet oxygen and hydroxyl radical are first formed in this reaction, which then reacts with luminol to produce excited luminol, thus light-emitting is produced. In order to further elucidate the possible CL mechanism, we study the possible products in the reaction via UV-visible absorption spectrum experiment. After adding 0.1g β -CD into the KMnO_4 solution (6.0×10^{-5} mol/L) in 0.04mol/L

NaOH media, the solution becomes green gradually as shown in Fig. 7. In Fig. 7, the two maxima peaks of KMnO_4 at 525nm and 545nm disappear [20], with addition of 0.1g β -CD into the solution. And at about 605 nm, a new absorption peak appears, which is assigned to the MnO_4^{2-} visible absorption [20]. Based on the above-described experimental results, KMnO_4 seems to be reduced to K_2MnO_4 in the reaction. With the addition of sample solution, hydroquinone and catechol are oxidized by hydroxyl radical and singlet oxygen to produce corresponding quinones [10], hence a decreased CL signal is observed (equation 4 and 5).

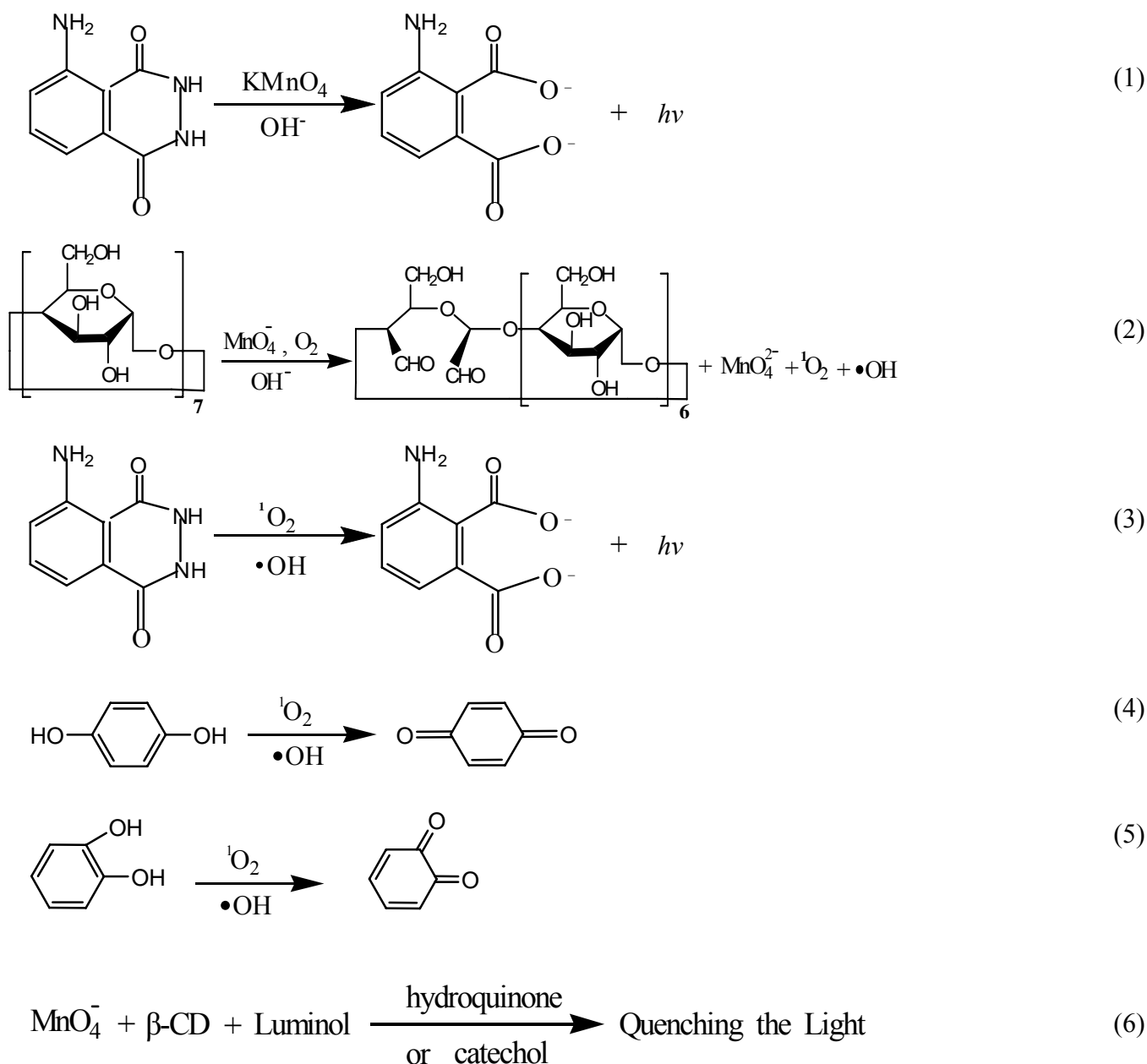

Scheme 1. Possible reaction process of the present system.

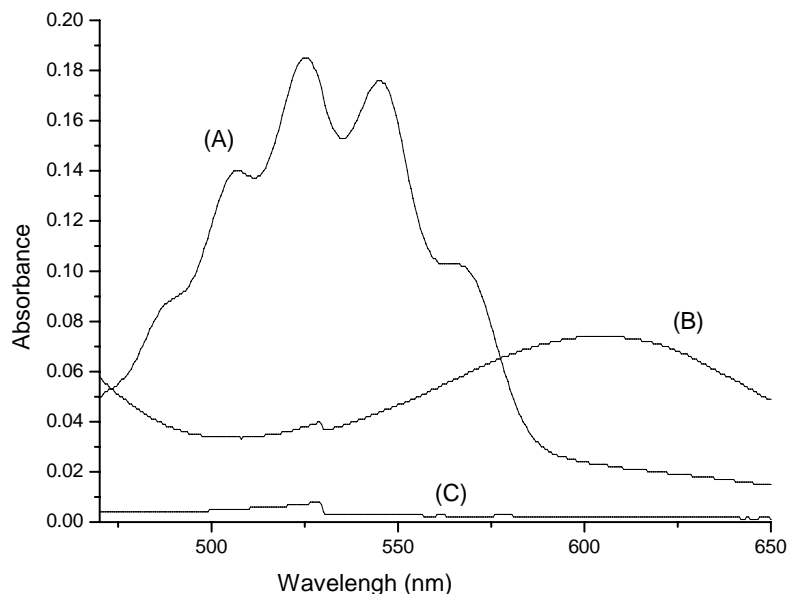

Figure 7. UV-vis absorption spectra: (A) KMnO_4 (B) $\text{KMnO}_4+\beta\text{-CD}$ (C) $\beta\text{-CD}$

4. Conclusions

A new flow-injection CL method is developed for the determination of hydroquinone and catechol, based upon the inhibitory effects on the luminol- KMnO_4 - β -cyclodextrin reaction in alkaline solution. The system exhibits good stability, reproducibility and satisfactory detection limit. After some pretreatments of industrial wastewater and river water mentioned above, the method can be applied to the determination of hydroquinone and catechol. The proposed method offers the advantages of simplicity, rapidity, and high sensitivity for the determination of hydroquinone and catechol, and can be adopted as an alternative to the existing methods. Further research work on this subject is still in progress, the CL reaction developed can be coupled with high performance liquid chromatography (HPLC) to simultaneously determine hydroquinone and catechol.

Acknowledgements

This study was supported by the National Natural Science Foundation of China (No. 20570542) and the Innovation Foundation of Sichuan University (No: 2006G006).

References

1. Rueda, M. E.; Sarabia, L. A.; Herrero, A.; Ortiz, M.C. Optimisation of a flow injection system with electrochemical detection using the desirability function Application to the determination of hydroquinone in cosmetics. *Anal. Chim. Acta.* **2003**, *479*, 173-184.
2. Cui, H.; He, C. X.; Zhao, G. W. Determination of polyphenols by high-performance liquid chromatography with inhibited chemiluminescence detection. *J. Chromatogr. A.* **1999**, *855*, 171-179.

3. Lavrent, K.; Julien, A.; Zofia, M.; Barry, D. Formation of Cyclopentadienyl Radical from the Gas-Phase Pyrolysis of Hydroquinone, Catechol, and Phenol. *Environ. Sci. Technol.* **2006**, *40*, 5071-5076.
4. William, S. S.; Robert, M. M.; Maurice, E. S.; Ralph, E. W. Pyrolytic Studies on the Contribution of Tobacco Leaf Constituents to the Formation of Smoke Catechols. *J. Agric. Food Chem.* **1982**, *30*, 372-374.
5. Steven, G. C.; Stephen, S. H.; T. C. T.; Dietrich, H. Roles of Tobacco Cellulose, Sugars, and Chlorogenic Acid as Precursors to Catechol in Cigarette Smoke. *J. Agric. Food Chem.* **1984**, *32*, 267-273.
6. Nagaraja, P.; Vasantha, R. A.; Sunitha, K. R. A new sensitive and selective spectrophotometric method for the determination of catechol derivatives and its pharmaceutical preparations. *J. Pharm. Biomed. Anal.* **2001**, *25*, 417-424.
7. Parham, H.; Pourreza, N.; Cheraghi, S. Kinetic-spectrophotometric determination of trace amounts of resorcinol based on its inhibitory effect on the formaldehyde catalyzed reaction between bromate and neutral red. *Anal. Lett.* **1999**, *32*, 1917-1926.
8. Wang, L. H.; Kuo, Y. P. Simultaneous quantitative determination of resorcinol and 1-naphthol in haircolor products by high-performance liquid chromatography. *Chromatographia*, **1999**, *49*, 208-211.
9. Sun, Y. G.; Cui, H.; Li, Y. H.; Lin, X. Q. Determination of some catechol derivatives by a flow injection electrochemiluminescent inhibition method. *Talanta*. **2000**, *53*, 661-666.
10. He, D. Y.; Zhang, Z. J.; He, C. Investigation on the interaction between dihydroxybenzene and Fe^{3+} - H_2O_2 -Rh6G system based on enhancing chemiluminescence. *Luminescence*, **2006**, *21*, 15
11. Kamil, M.; Antonije, O.; Pavel, M.; Zbyne'k, V. Flow-injection chemiluminescence determination of formaldehyde in water. *Talanta*. **2007**, *71*, 900-905.
12. Cao, W.; Yang, J. H.; Sun, C. X.; Zhang, Z. J.; Gao, Q. F. Flow-injection-chemiluminescence method for the determination of penicillin G potassium. *Luminescence*. **2005**, *20*, 238-242.
13. Lv, Y.; Zhao, R.; Zhu, Z. L.; Xu, X.S.; Zhang, X. R. A novel chemiluminescence method for the determination of orciprenaline based on ferricyanide-rhodamine 6G. *Luminescence*. **2005**, *20*, 298-302.
14. Yao, H.; Sun, Y. Y.; Lin, X. H.; Cheng, J. H.; Huang, L. Y. Flow-injection chemiluminescence determination of catecholamines based on their enhancing effects on the luminol-potassium periodate system. *Luminescence*. **2006**, *21*, 112-117.
15. Cui, H.; Xie, C. G.; Lai, C. Z. A novel chemiluminescent method for determination of phloroglucinol. *Luminescence*. **2003**, *18*, 318-323.
16. Liu, E. B.; Xue, B. C. Flow injection determination of adenine at trace level based on luminol- $\text{K}_2\text{Cr}_2\text{O}_7$ chemiluminescence in a micellar medium. *J. Pharm. Biomed. Anal.* **2006**, *41*, 649-653.
17. Du, J. X.; Li, Y. H.; Lu, J. R. Flow injection chemiluminescence determination of polyhydroxy phenols using luminol-ferricyanide/ferrocyanide system. *Talanta* **2001**, *55*, 1055-1058.
18. Lu, Y.; Zhang, Z. J.; He, D. Y.; Hu, Y. F. Flow injection chemiluminescence determination of polyhydroxy phenols in the presence of Rhodamine B as a sensitizer. *Chem. Anal.* **2003**, *48*, 959-966.

19. Song, Z. H.; Wang, L. Resorcinol chemosensor based on detection of chemiluminescence with immobilized reagents. *Microchem. J.* **2001**, *68*, 47-52.
20. Du, J. X.; Liu, W. X.; Lu, J. R. Investigation on the chemiluminescence behavior of alkaline earth metal ions Mg^{2+} , Ca^{2+} , Sr^{2+} and Ba^{2+} in luminol-permanganate reaction. *Acta Chimica Sinica.* **2004**, *14*, 1323-1326.
21. Li, Y. H.; Niu, W. F.; Lu, J. R. Sensitive determination of phenothiazines in pharmaceutical preparation and biological fluid by flow injection chemiluminescence method using luminol– $KMnO_4$ system. *Talanta* **2007**, *71*, 1124–1129.
22. Emil, H. W.; Oliver, Z.; Heinz, H. K.; John, H. M. H. Chemiluminescence of Luminol and Related Hydrazides : The Light Emission Step. *J. Am. Chem. Soc.* **1964**, *86*, 941-942.
23. Cao, Z. J.; Choiwan, L.; Lu, J. Z. A general chemiluminescence method for the determination of surfactants based on its quenching effect on the luminol- $NaIO_4$ -cyclodextrin reaction. *Analyst.* **2004**, *129*, 1262-1266.